

LAMP® FD50-H SLIDING DOOR SYSTEM Installation Manual (Surface mount roller Type for Pocket Door, with Tow-way Soft Close)

Part No.FD50DHCMP-PD

Thank you for purchasing Sugatsune products.

Read the instructions carefully first to ensure correct installation.

After reading the instructions and installing the product, keep this guide at hand for easy reference at any time.

ABOUT THE PRODUCT

- This product is parts set for sliding door system for indoor use.
- The track can be divided for easy maintenance after installing.

SPECIFICATIONS

Door width	774 - 1500mm
Max. Door height	2400mm
Min. Door thickness	30mm
Max. Door weight	50kg/door

- The closing speed of the soft closing type door may change due to ambient temperature, operating method or installation quality.
- Recommended ambient temperature range is 5 to 40 degrees centigrade.
- Door retraction: Retract door slowly.

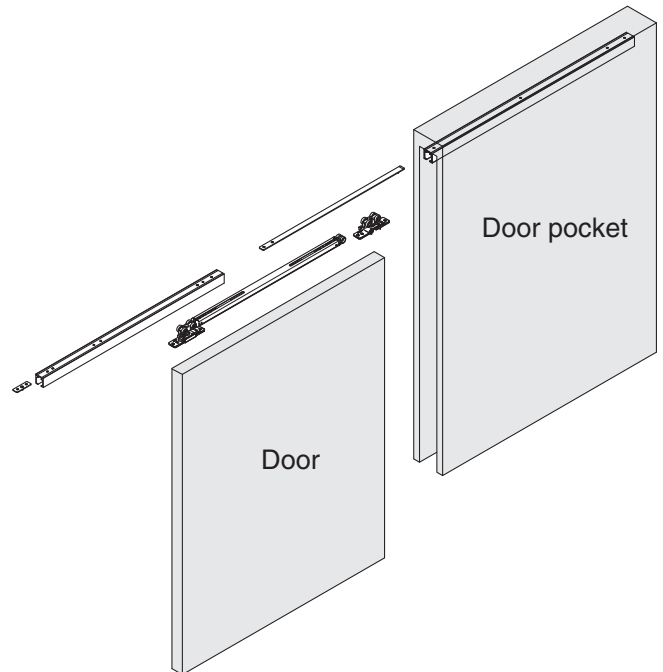

FOR YOUR SAFETY WORK AND OPERATION

Meaning of symbols

 Warning Caution	 Prohibited	 Required
--	---	---

WARNING: If these warnings are not followed, it may result in death or serious injury.

- ❗ This (sliding door system) should be installed by an experienced person who has correct knowledge. If the system is not installed correctly, the door will not operate smoothly, and or may cause injury.
- ❗ It is necessary to manufacture the frame with sufficient strength so it endures the weight of the door and impact shocks upon opening/closing the door. Also make sure to only use the designated screws and to fasten them firmly. A frame with poor strength or loose screws might result in improper and slower movement of the door. In the worst case, the door might drop down and cause injury.
- ⊘ Do not try to use this product for any other purposes than originally intended for. Do not use the parts for applications that are out of specification.
- ⊘ Do not disassemble nor modify any parts other than those described in this document.

Caution: If these cautions are not followed, it may result in injury or damage.

- ❗ Make sure to follow the designated measurements and specifications as well as horizontal and verticals angles. Make sure that frame and door are not warped nor bent, since it may affect the movement of the door.
- ❗ If cutting any parts, make sure to remove any burr before installation. Also check the upper track for any left-over burr or scrap and remove these.
- ❗ This (sliding door system) is a part for furniture fittings. After installation, make sure to test the finished product thoroughly to ensure that it is well-functioning and safe.
- ❗ Make sure to test the screws for slack at regular intervals (one month from first usage, half year and then one time every year is recommended).
- ❗ When installing "pocket door" specification, make "easy-maintenance" structure. For example, use removable panel.
- ❗ We recommend that the installation is carried out by two people, in order to ensure proper installation and avoid unnecessary stress on the parts.

Confirmation before assembly

- Check that dimensions of frame, floor, door and track are correct.
- Check that frame and floor are not inclined.
- Check that door is processed correctly.
- Check that door is not warped.
- Check that all parts are prepared.

! Remove any dirt or aluminum chips from the track as they would damage the rollers and cause noise during operation.

1 Cutting Track and Hole Processing

When using 1260mm track

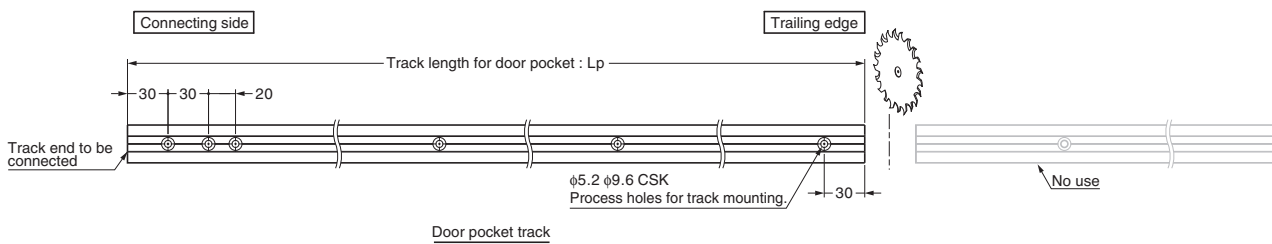
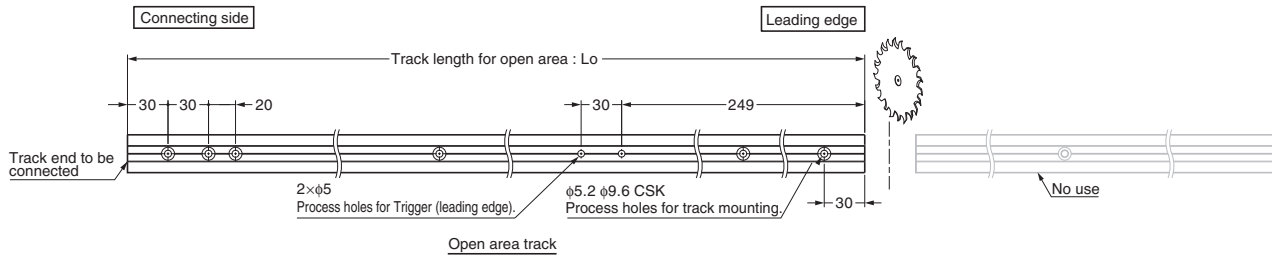

When cutting from a long rail (1860mm, 2760mm, 3960mm)

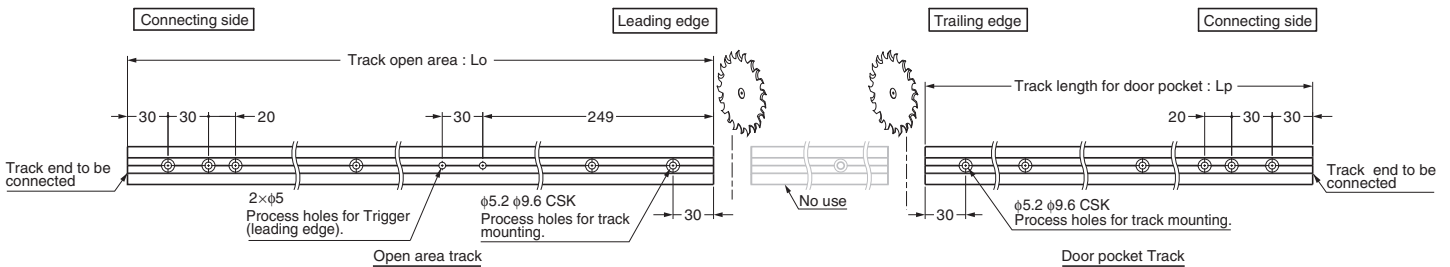

! When cutting, use reinforcer for the track to prevent deformation at cut section.

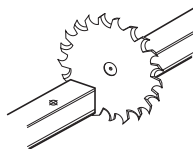

2 Installing Door Pocket Track

Mount Door pocket rail to the upper frame.
Fix it with attached screws.

! Remove any dirt or aluminum chips from the track

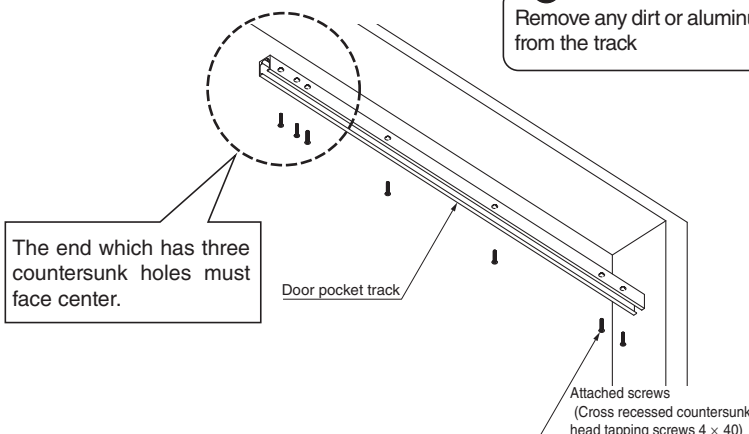

Assemble the cover panel to the door pocket after mounting the Tracks

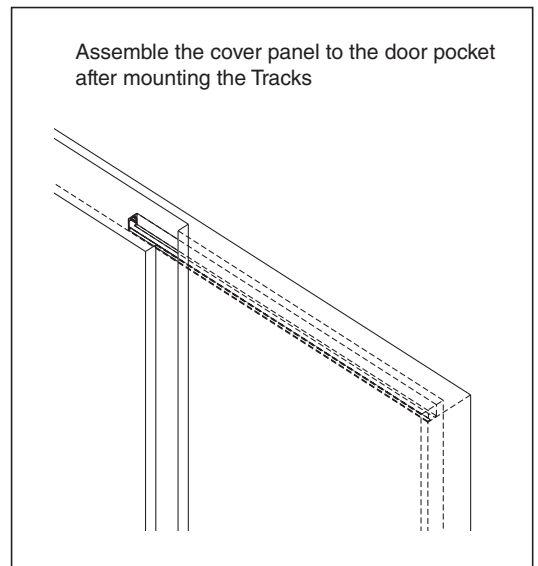

3 Installing Holder

Remove Bracket and holder from Upper roller.
Fix the upper roller, bracket with attached screws.

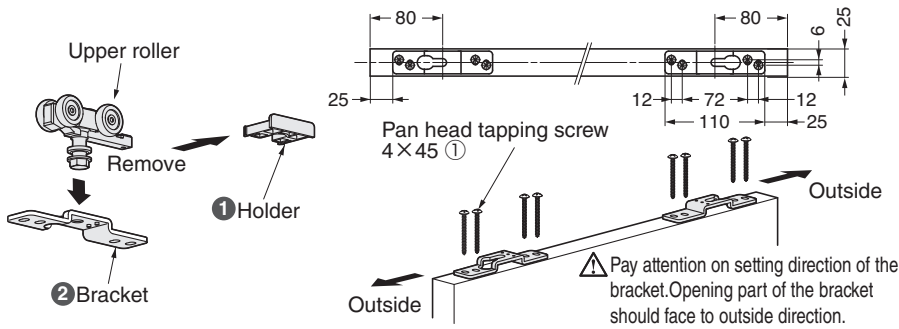

4 Installation Of Casing And DoorBottom Guide Track

Cut door bottom guide track with same length of door. Firmly insert the guide track into notch at bottom of door.
And, fix it with countersunk head tapping screws 4x20 (to be prepared separately).

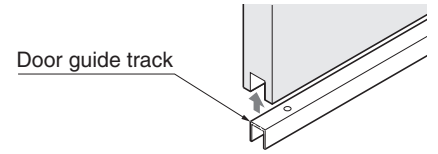

5 Installing Pocket Trigger

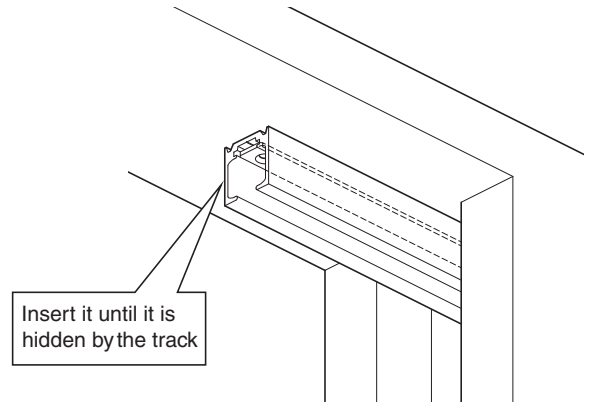
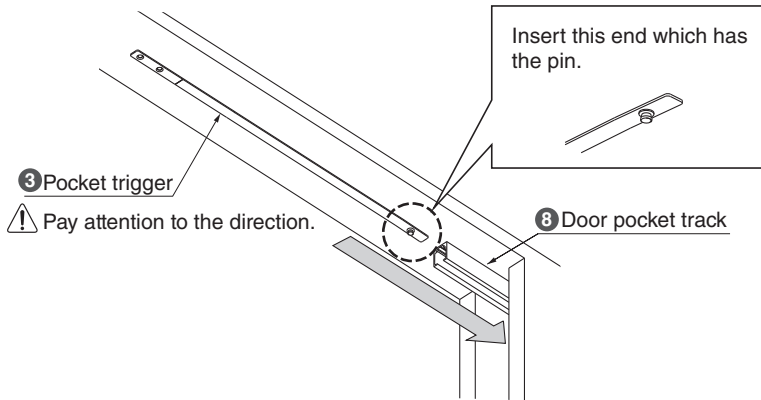

6 Confirmation Before Installing The Tow-way Soft Closer

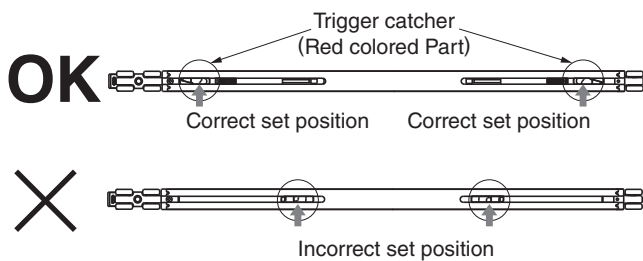

If the position is wrong, pull back the trigger catcher to the correct position using 6mm diameter hard bar.



If the closer is installed without conformation, it will cause the trouble such as no-sliding of door.

7 Assembly Of Parts For Open Area Track.

Assemble the parts in order of 1 to 3 with care of direction.
You can insert the parts smoothly from the connecting end which has no burr.

1 Remove any dirt or aluminum chips from the track.

2 Tape around upper roller and upper track to prevent inserted parts from moving.

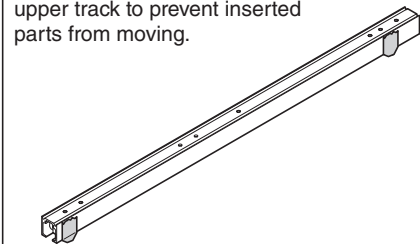

The edge which has three countersunk holes is the end to be connected.

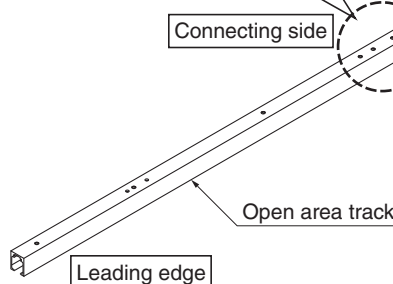

Tow-way Soft Closer
3 Pay attention to the direction.

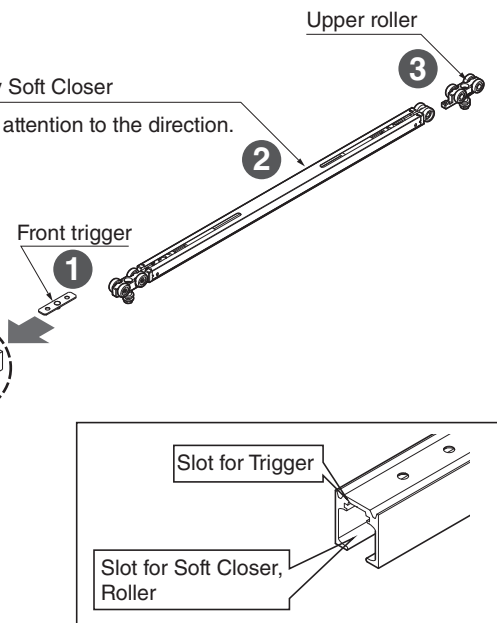

8 Installing Open Area Track.

[1] Positioning

Align the track end to the end of the door pocket track.

Pull out the Pocket trigger from the door pocket track, and insert it to the open area track.

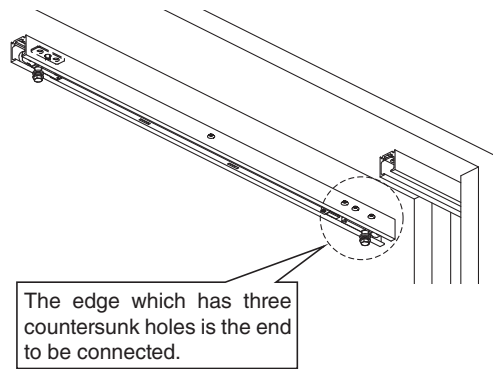

Overlap the two countersunk holes on the Pocket trigger and the two holes on the Upper track nearby the open area.

⚠ Insertion of the trigger may be difficult if the rails are not aligned.

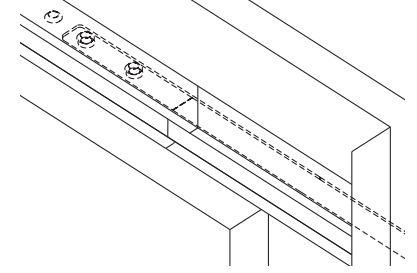

When sliding Pocket trigger, use a screwdriver.
⚠ Take care not to damage the track when sliding the Pocket trigger with screwdriver which jumps out of the hole. Scratches on the running track may cause a noise of rollers during operation.



[2] Fixing

Fix the Open area track and Pocket trigger with provided screws in order of ① to ⑤.

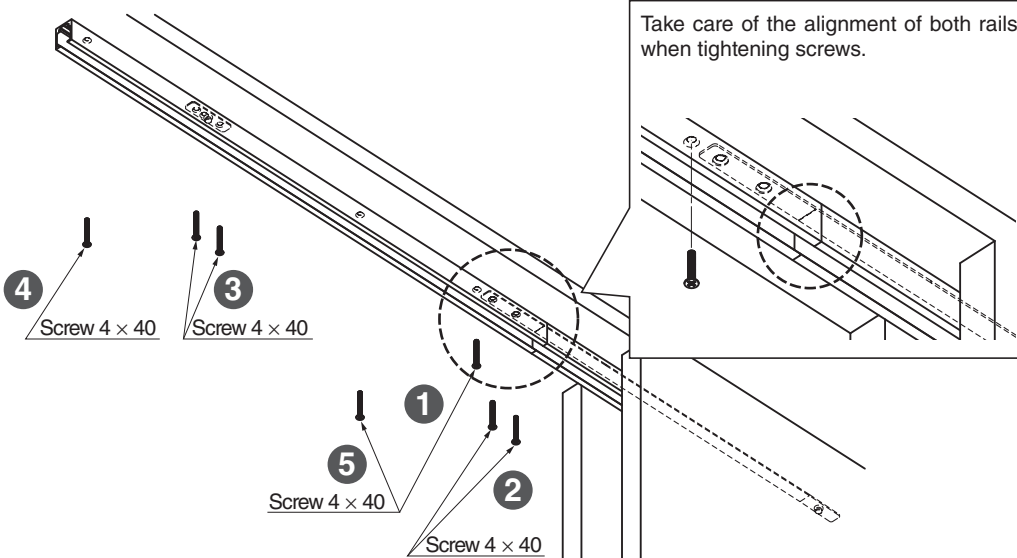

⚠ Be careful about the misalignment of the tracks. Tighten the screws firmly.

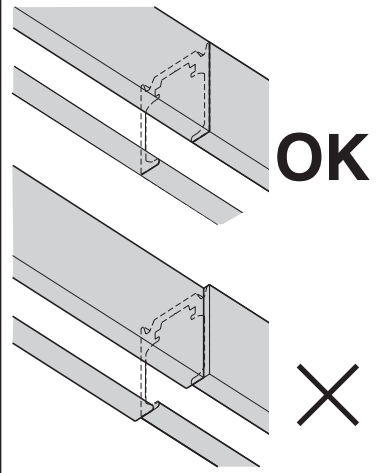

After fixing the track, move rollers and check if there's any misalignment or gap between the track.

9 Installing Floor Guide

Position floor guide just below the center of upper track.

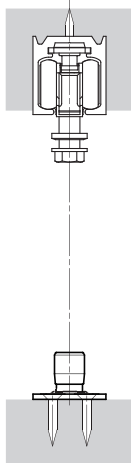

⚠ The figure shows the position of the model which has margin.

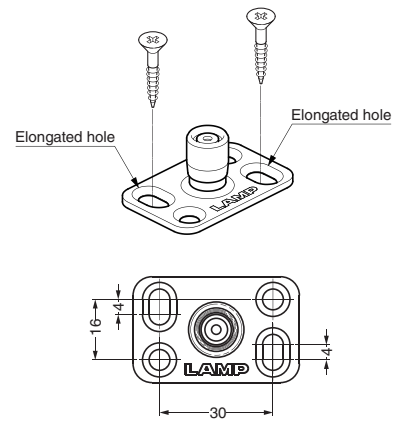
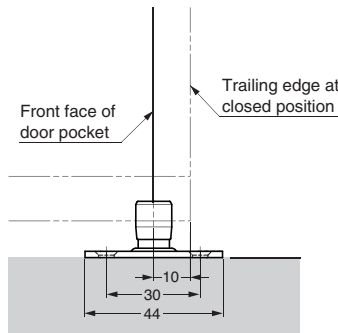

10 Hanging Door

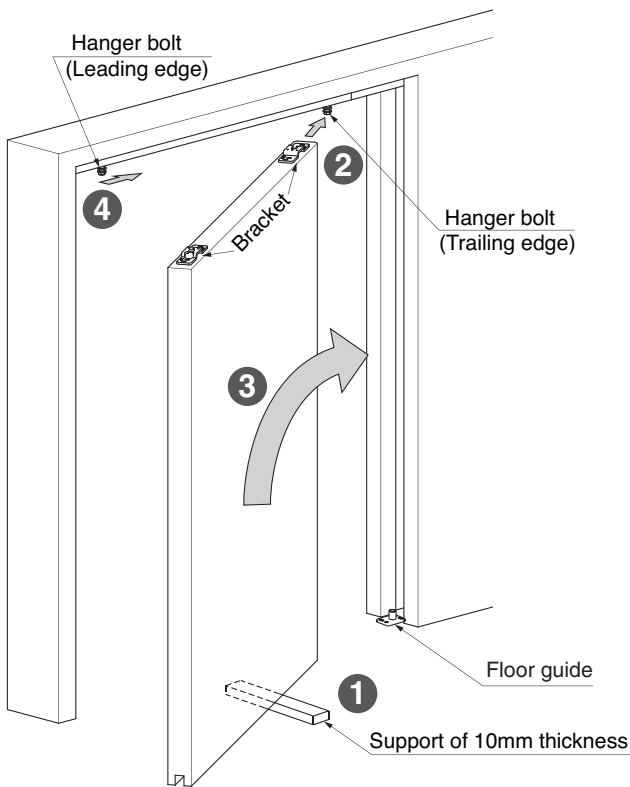

Ensure that hanger bolt head is in straight position as shown for smooth fixation of Holder.

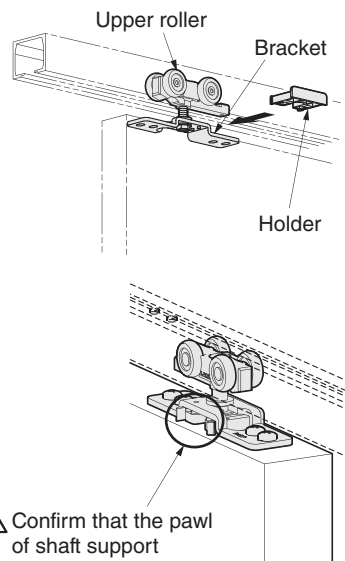

⚠ Confirm that the pawl of shaft support Holder catches opposite side of the holder.

11 Confiration of Sliding Door Closer Operation

Remove the support under the door. Slowly move the door toward door head, and confirm that sliding door closer starts its function at approx. 100mm before full-close position.

Also, confirm that the door tail vertical frame closer starts its function at approx. 50mm before full-close position.

If the closer is not working correctly, check the Troubleshooting section.

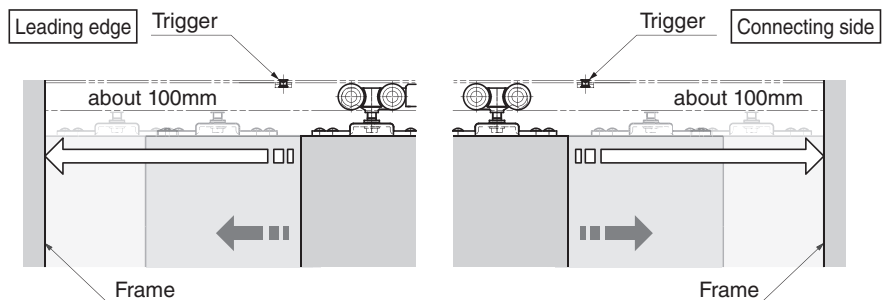

⊘ Do not close the door with excessive force. It may cause damage or malfunction of soft close mechanism.

12 Adjusting Door Position

1 Remove holder

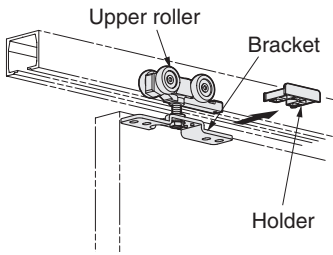

2 Adjust door such that door is parallel to upper track with 8mm clearance between door and floor.

Vertical adjustment range: 8mm

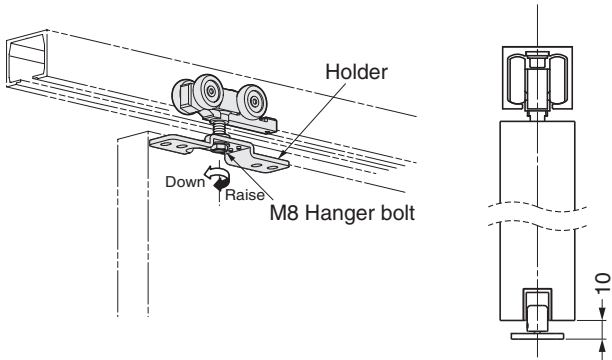

Do not turn adjustment screw more than adjustment range.

3 Fix holder

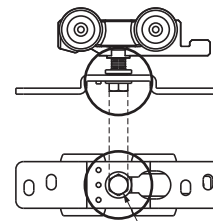
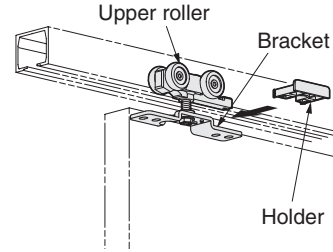

Ensure that hanger bolt head is in straight position as shown for smooth fixation of holder.

13 Adjusting Floor Guide (Adjust Range : 4mm)

If the friction between the door and floor guide when opening /closing the door, remove the door, then loosen the fixing screws on the floor guide and adjust the position.

Adjustment range:4mm

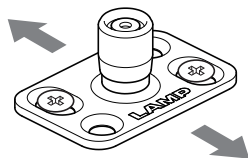

Tighten 4 screws after the positioning.

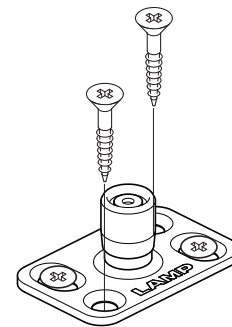

SUPPLEMENT 1 How to Remove Door, Track

[1] How to remove door

- ① Put a support of 10mm thickness under the door.
- ② Remove holder
- ③ Pull out the Hanger bolt at leading edge from the Bracket.
- ④ Pull out the door, while taking care of scratching with the door pocket.
- ⑤ Pull out the Hanger bolt at trailing edge from the bracket.

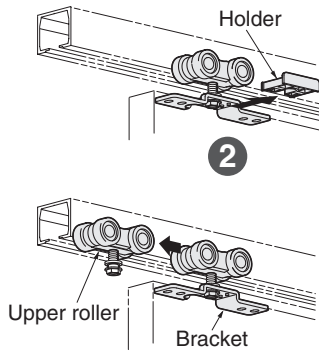

⚠ Be careful so the door does not fall down.

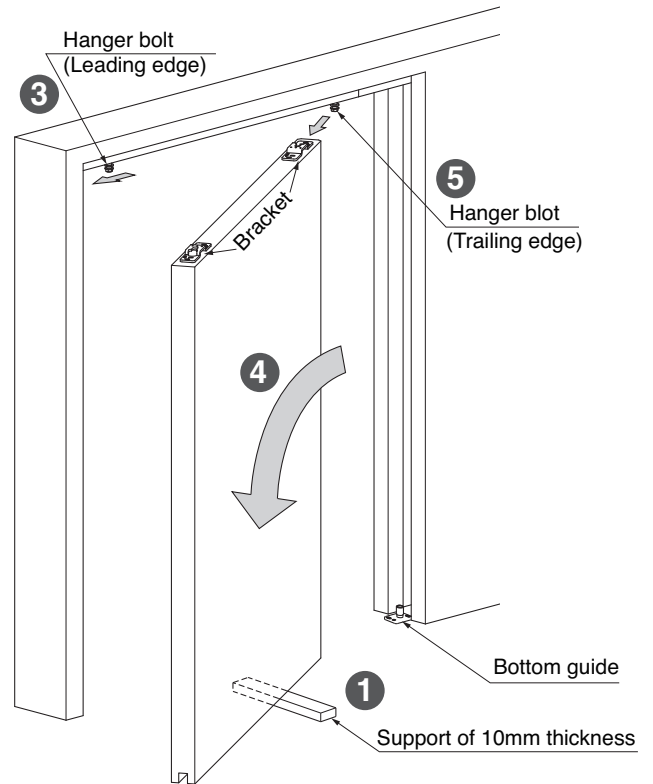

[2] How to remove Upper track

- ① Remove the screws on the Pocket trigger.
- ② Slide the Pocket trigger into the Door pocket track.
- ③ Remove the Open area-track.

⚠ If you try to remove the Open area track without sliding the Pocket trigger into the Door pocket track, the trigger can become deformed.

Hold the Open area track when removing the last screw.

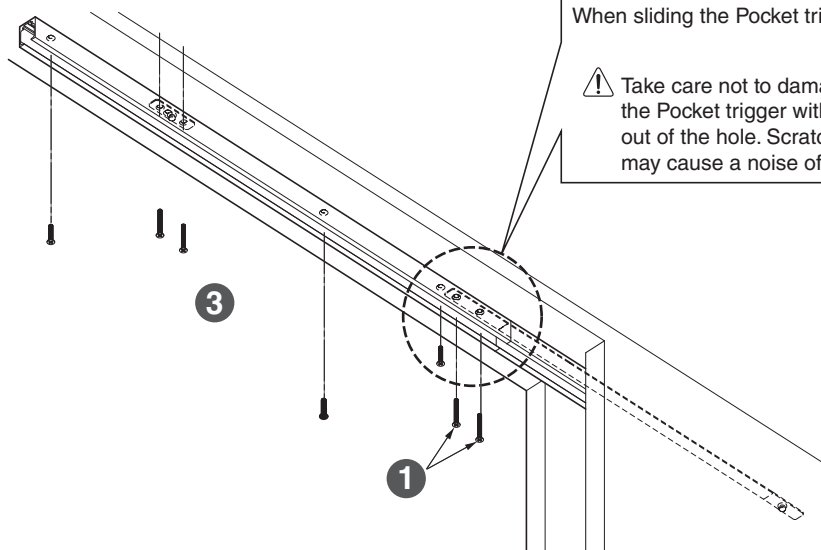

When sliding the Pocket trigger, use a screwdriver etc.

⚠ Take care not to damage the track when sliding the Pocket trigger with screwdriver which jumps out of the hole. Scratches on the running track may cause a noise of rollers during operation.

SUPPLEMENT 2 How to Shift The Connecting Position of The Tracks.

[1] When determining trigger position on site

- (1) Put a mark on the Open area track with reference to the front end of the door at full opened position.
(We recommend to put the mark on a masking tape.)
- (2) Drill additional holes for trigger on the Open area track.
Remove the door according to the procedure **SUPPLEMENT 1**
How to remove door, then remove the Open area track.
- (3) Drill additional holes for trigger on the open area track.
(See the below drawing)

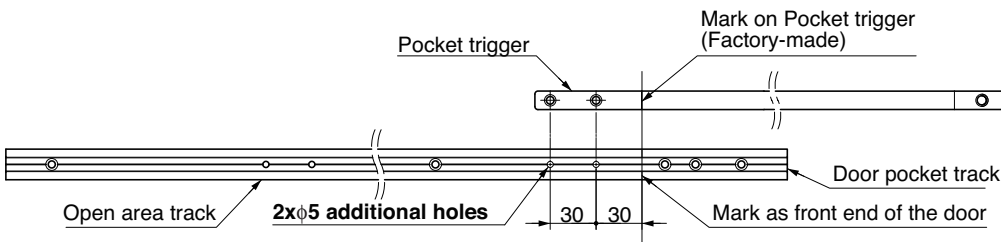
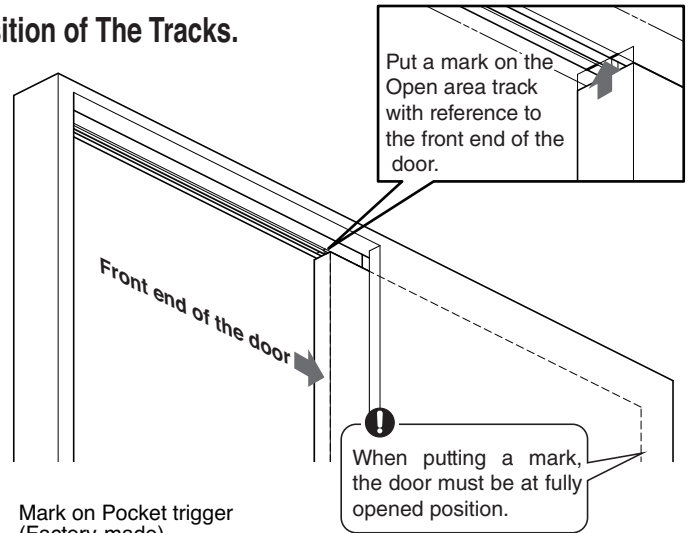

- (3) Fixing Open area track
Follow the right below figure, since the working sequence is different from regular process.
- (4) Hanging door
Refer to the procedures **2** and following procedures on page 2.

Working sequence for fixing Open area track

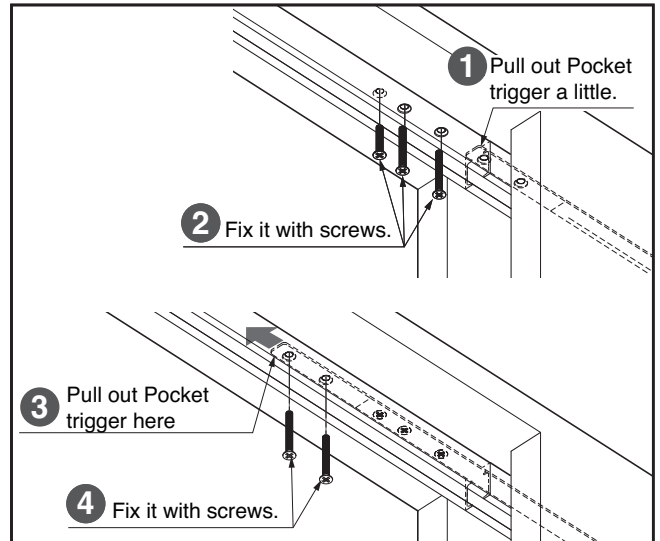

[2] How to process holes for Pocket trigger in advance

[Example]

Door pocket track with its length equal to the width of door pocket.

- (1) Drill holes for Pocket trigger according to below drawing.
- (2) Fix Open area track, while following the right above figure, since the working sequence is different from regular process.

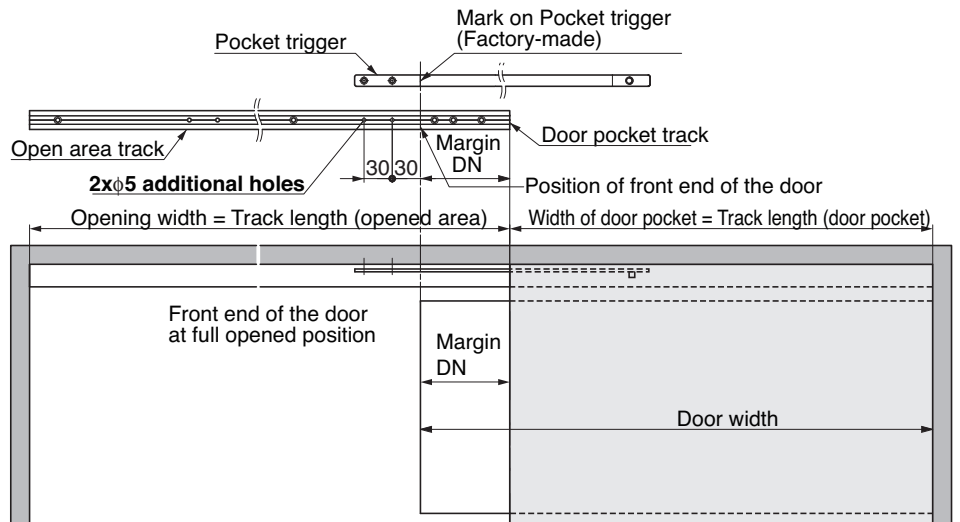

Final confirmation Confirm that all screws are securely tightened. And, confirm that all screws are used without mistake.

PERIODICAL INSPECTION

- Clean inside of track.
- Check upper space and lower space of the door. If necessary, correct the space.

■ TROUBLESHOOTING

Trouble	Checkpoint	Solution
Door stops during soft closing	Check if door bottom contacts with floor.	Confirm that track fixing screws are not loosened. Then, adjust door height such that clearance between door bottom and floor becomes 6 - 13 mm.
	Check if upper track is set horizontally.	Using a level gauge, reset upper track horizontally.
	Check if mohair seal is installed.	Reduce the friction between mohair seal and door.
No soft closing	Check if trigger is installed.	Install trigger to correct position.
	Check if door is closed by excessive force.	Do not close door by excessive force and it may damage soft closer.
	The position of trigger catcher might change to the incorrect position inside the track. (See section 「 6 」.)	Slowly moving the door toward door head side, then push the door firmly. Repeat this action to the opposite side as well. If it is still not improved, check the status of trigger catcher in section 「 6 」.
Abnormal noise during operation	Check if door touches other parts.	Correct door position to avoid contact to other parts.
	Check track rollers for aluminum dust.	Remove the track and pull out the roller. Then, clean the roller.
	Check for loose screws retaining the upper track.	Tighten the screw.
Heavy door operation	Check if door touches adjacent parts.	Correct door position to avoid contact to other objects. Adjust position of floor guide or stopper.
	Check if door is warped.	Use a door without warp.
Door does not move.	Check track retaining screws for looseness.	Roller touches with screw. Retighten screws to free the roller.
Door stops or caught during operation.	Check if any gap or misalignment between the tracks.	Correct the misalignment or gap.

SUGATSUNE KOGYO CO.,LTD.
Tokyo, JAPAN
Phone: +81 (0)3 3866 2260
E-mail: export@sugatsune.co.jp

SUGATSUNE EUROPE GmbH
Düsseldorf, GERMANY
Phone: +49 211 53812900
E-mail: info@sugatsune.eu

SUGATSUNE SHANGHAI Co., LTD.
Shanghai, CHINA
Phone: +86 21 3632 1858
E-mail: lamp@sugatsune.com.cn

SUGATSUNE AMERICA, INC.
California, USA
Phone: +1 310 329 6373
E-mail: sales@sugatsune.com

SUGATSUNE KOGYO (UK) LTD.
Reading, UK
Phone: +44 118 9272 955
E-mail: sales@sugatsune.co.uk

SUGATSUNE KOGYO INDIA PRIVATE LIMITED
Mumbai, INDIA
Phone: +91 22 28314490/91
E-mail: sales@sugatsune.in

Guangzhou, CHINA
Phone: +86 20 6639 3552
E-mail: lamp@sugatsune.com.cn

Chicago, USA
Phone: +1 312 461 1081
E-mail: chicagoshowroom@sugatsune.com