

MultiMo FLAT™

Instruction Manual <for wood doors> PAT.

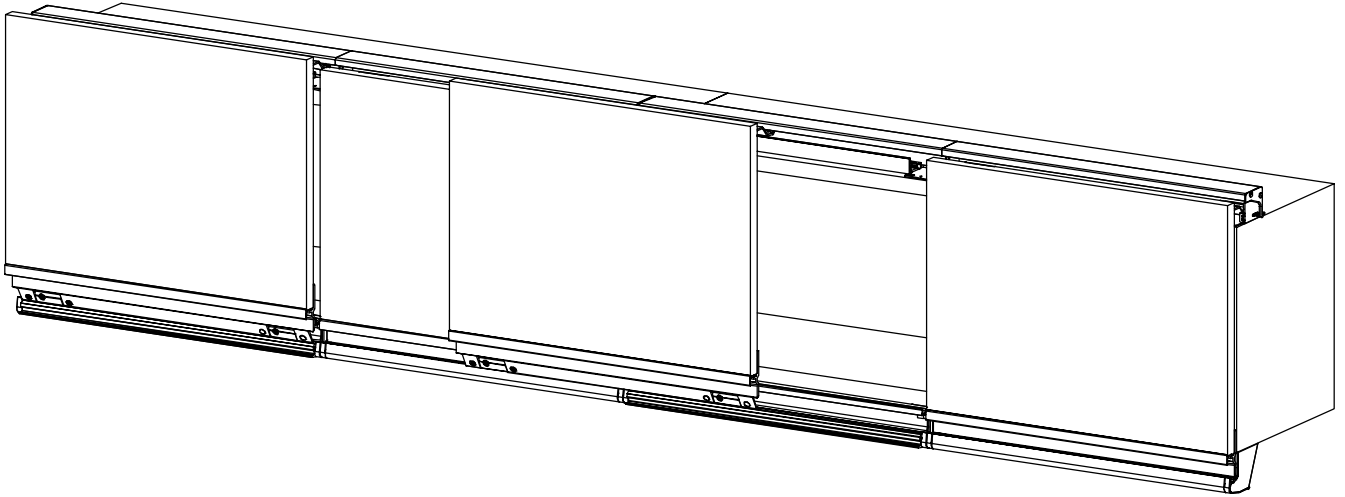

Thank you for purchasing this MultiMo Flat system for wood doors by SUGATSUNE. Before proceeding with the installation, please read this instruction manual carefully for the best possible end result and ensure your safety. Faulty installation may result in injury. Please keep this instruction manual at hand for future reference.

⚠ WARNING Failure to observe the following precautions may result in injury and/or lead to damage to surrounding cabinets or fittings.

WARRANTY:

- SUGATSUNE guarantees the quality of this product as for all its parts. It cannot however guarantee the assembly of the end product as a whole.
- This product was manufactured and delivered with our utmost care. Should you however find any defect, please contact your dealer immediately.
- SUGATSUNE warrants that this product to be free from defects for a period of one (1) year from the date of delivery. SUGATSUNE liability is limited to the replacement of this product by a similar one free from defect. SUGATSUNE liability does in no case extend to the replacement of the installation and/or cabinet as a whole.
- SUGATSUNE cannot be held liable for injury or trouble caused by a use different than the original purpose.

INSTALLATION PRECAUTIONS:

- Always clear the area before proceeding with the installation.
- Ensure that doors sizes, weights and material correspond to the specifications stated in this manual.
- We recommend that the installation be made by your local dealer or a professional hardware installer.
- Do not strike parts or throw them on the floor as it may impair the smooth operation of the system.
- Thoroughly clean rails and rollers.
- We recommend that the installation be carried out by two people, in order to ensure safety and avoid unnecessary stress on the parts.
- Use suitable screws to ensure a secure installation of the cabinet and doors.

OPERATION AND MAINTENANCE PRECAUTIONS:

- Periodically check for and tighten any loosened screw.
- Do not use excessive force when operation the system.
- Closing of the door can only be done when they are in front of their storage position as shown Page 11, Fig. 9-6.
- Never attempt to disassemble or modify the system.
- Some dimensions and specifications may be changed without notice for improvement or safety reasons. Please check specification details on actual product.
- For cleaning, use a dry soft cloth. When removing persistent stains, wipe them by using cloth impregnated with diluted mild detergent. Wipe clean with damp cloth and, finally, with dry one.
- Never use metal brush or polishing powder for cleaning as this may scratch or remove the protective finish on the surface.

Contents

1. Product specifications	2
2. Parts list	2
3. Installation	
1. Dimensions	
(1) Cabinets	3
(2) Doors	3
2. Overview	
(1) Procedure	4
(2) Cabinet and doors requirements.....	4
Step 1 Lower rail installation	5
Step 2 Upper rail installation	6
Step 3 Door fittings installation	7
Step 4 Doors installation.....	8
Step 5 Adjustments	9
4. Removal procedure	10
5. Troubleshooting	11
6. Memo & Contact	12

Product specifications:

Cabinet width	Door width	Door height		Door thickness	Door weight					
					No.2 ^(*)	No.3 ^(*)	No.4 ^(*)	No.5 ^(*)	No.6 ^(*)	No.7 ^(*)
300 ⁺² ₋₀ mm	297 ⁻⁰ ₋₁ mm	300~600	Cabinet height +31 ^{±1.5} mm	15~23mm	1.7~2.6					
450 ⁺² ₋₀ mm	447 ⁻⁰ ₋₁ mm	300~900			1.6~2.5	2.6~3.5				
600 ⁺² ₋₀ mm	597 ⁻⁰ ₋₁ mm				2.5~3.4	3.5~4.4	4.5~5.4			
900 ⁺² ₋₀ mm	897 ⁻⁰ ₋₁ mm				4.3~5.2	5.3~6.2	6.3~7.2			

(*) The number indicated in table is the one figuring at the end of the product code (MFS-PN450/S3)

Parts list:

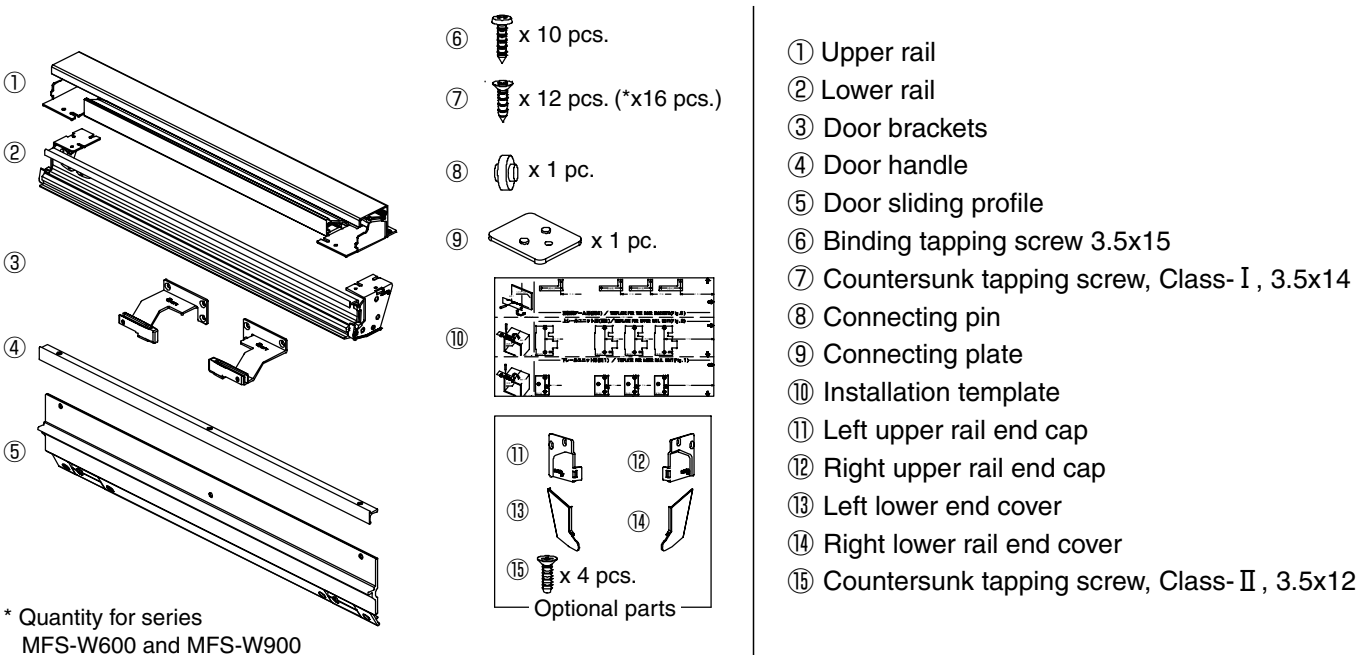

Installation:

1. Dimensions

(1) Cabinet

Upper rail ① installation

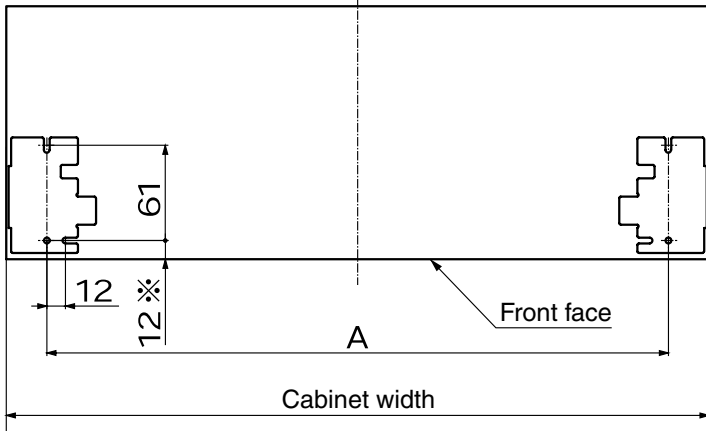

Lower rail ② installation

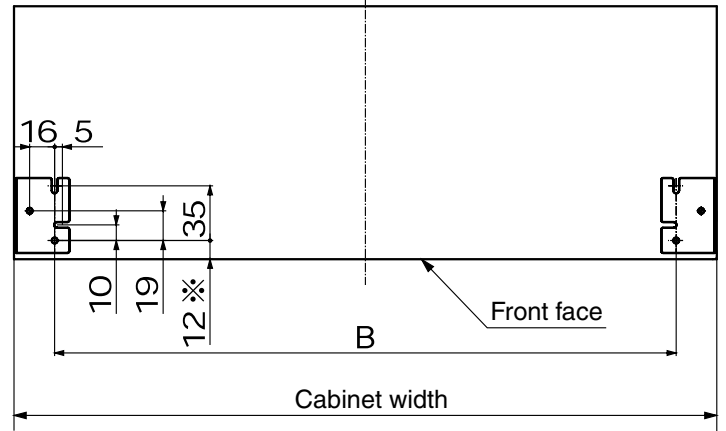

Cabinet width (mm)	A	B
300 ⁺² ₋₀	248	248
450 ⁺² ₋₀	398	398
600 ⁺² ₋₀	548	548
900 ⁺² ₋₀	848	848

(2) Doors

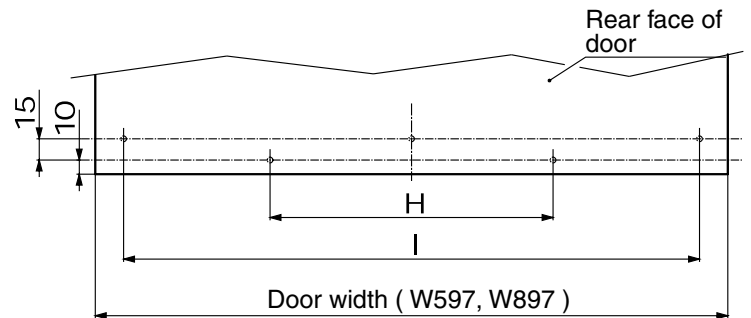
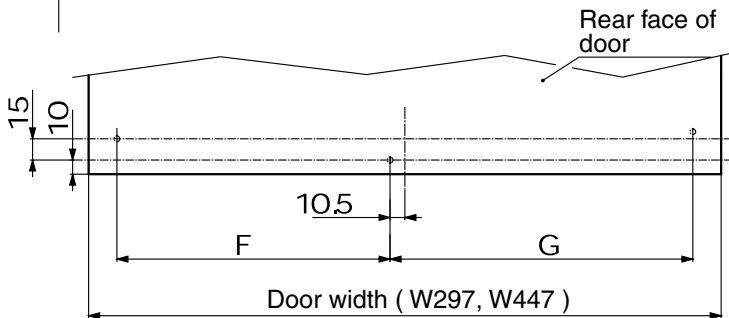
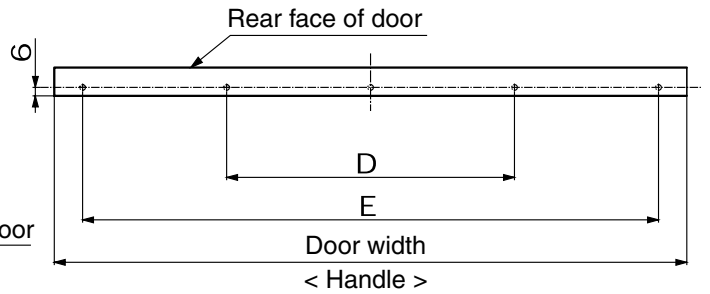
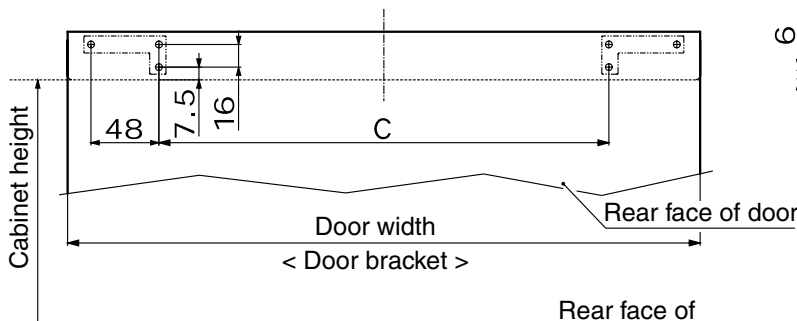

< Door sliding profile >

Door width (mm)	C	D	E	F	G	H	I
297 ⁺⁰ ₋₁	168	—	257	118	139	—	—
447 ⁺⁰ ₋₁	318	—	407	193	214	—	—
597 ⁺⁰ ₋₁	468	278.5	557	—	—	300	557
897 ⁺⁰ ₋₁	768	428.5	857	—	—	400	857

2. Overview

(1) Procedure

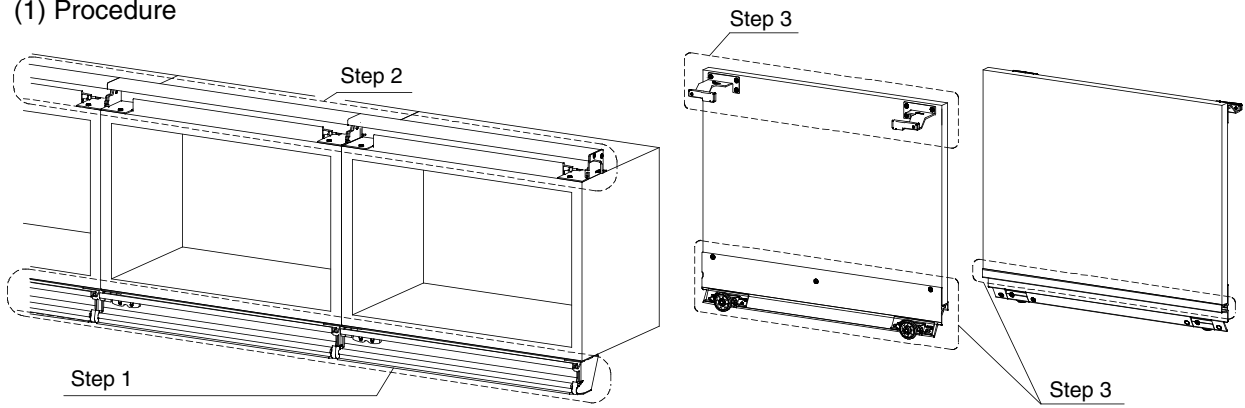

- Step 1: Lower rail ② installation
- Step 2: Upper rail ① installation
- Step 3: Door fittings ③④⑤ installation

- Step 4: Doors installation
- Step 5: Adjustments

(2) Cabinet and doors requirements

◇ Doors:

Doors must meet height, width and weight requirements shown in the “Product specifications” on page 2 of this manual.

Doors should not warp more than 2mm both vertically and horizontally (Fig. 1-1).

Doors should be strictly rectangular (Fig. 1-2)

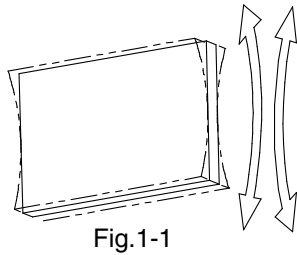

Fig.1-1

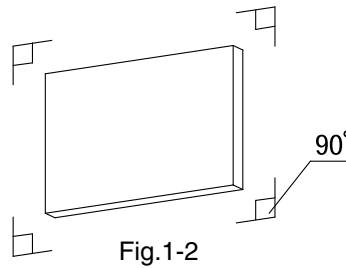

Fig.1-2

◇ Cabinets:

Cabinet modules should not warp (Fig.1-3).

Cabinet modules should be rectangular (Fig. 1-4)

Assembly of the cabinet modules should be straight and level (Fig. 1-5)

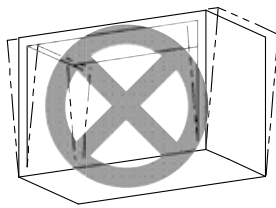

Fig.1-3

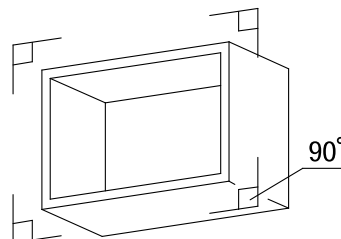

Fig.1-4

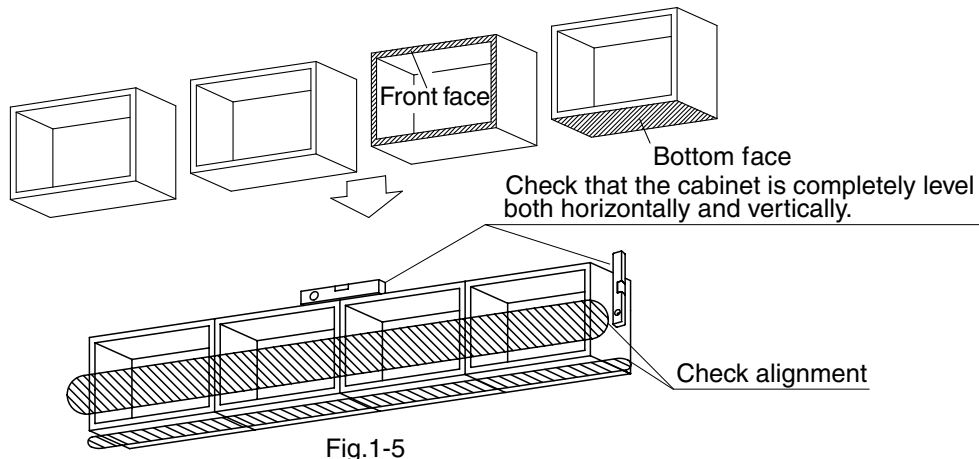
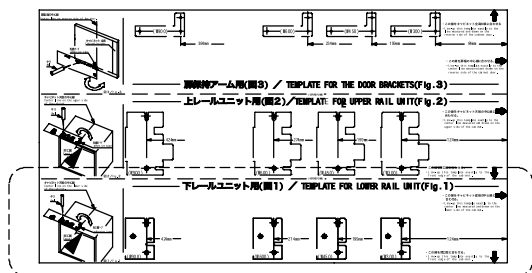

Fig.1-5

STEP 1: Lower rail installation



Portion to be used for fixing lower rail

Fig. 2-1

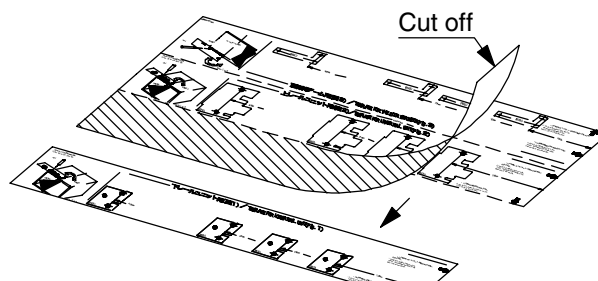

Fig. 2-2

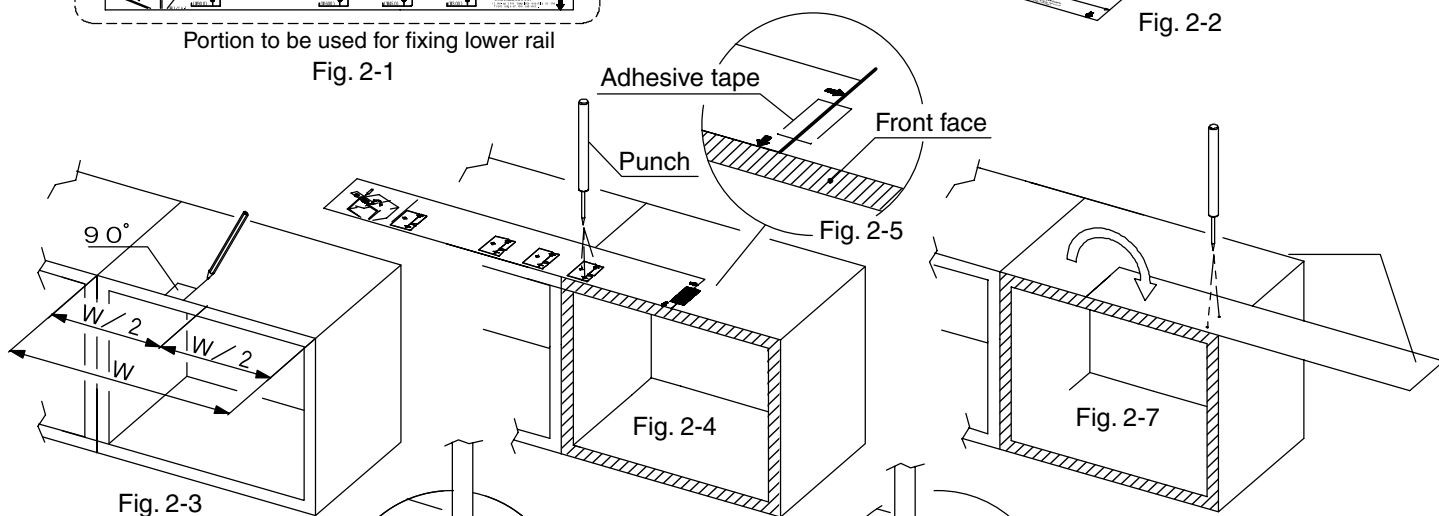

Fig. 2-3

Fig. 2-4

Fig. 2-5

Fig. 2-7

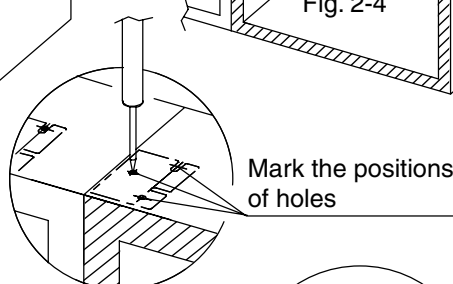

Fig. 2-6

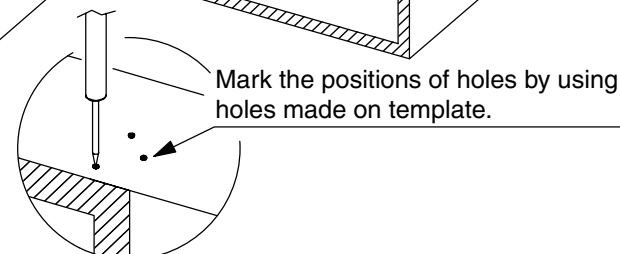

Fig. 2-8

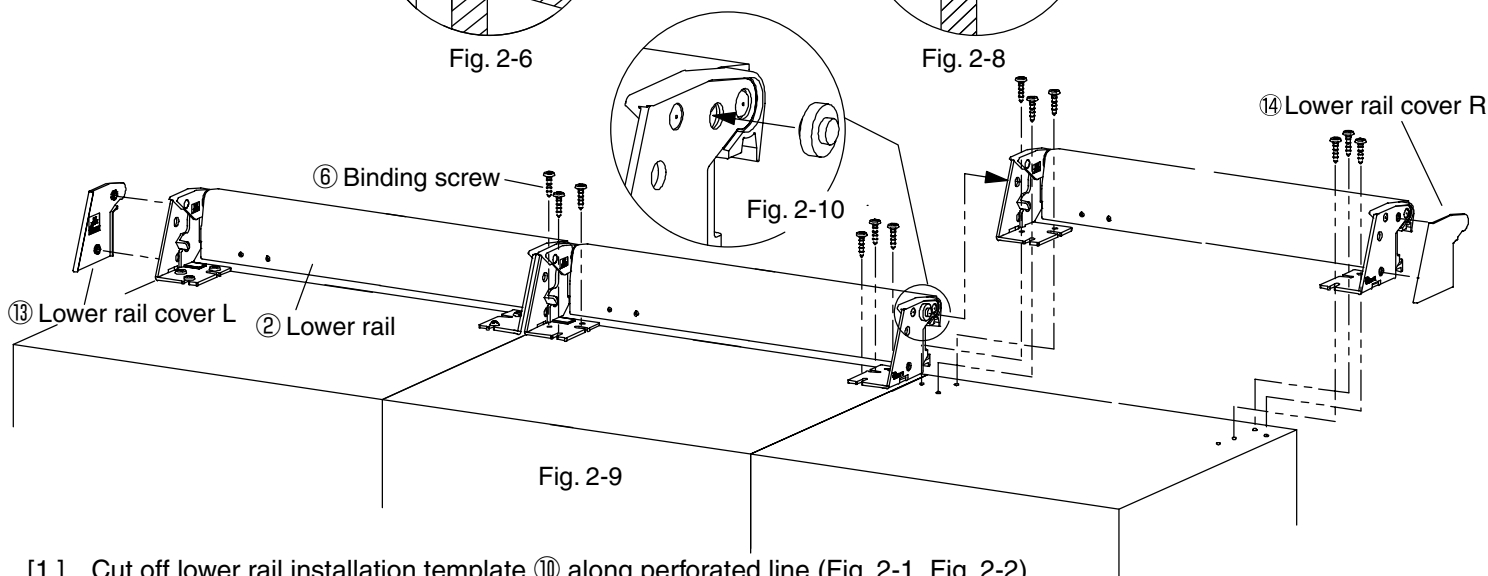
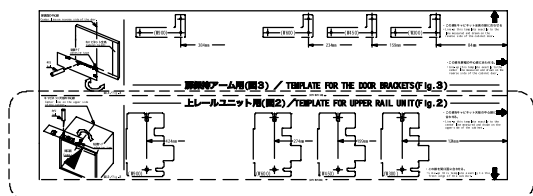

Fig. 2-9

Fig. 2-10

- [1.] Cut off lower rail installation template ⑩ along perforated line (Fig. 2-1, Fig. 2-2)
- [2.] Turn cabinet upside down and draw the width cabinet center line on the bottom of the cabinet (Fig. 2-3)
- [3.] Align the edges of template ⑩ with the center line marked in [2] and the front edge of the cabinet. Secure template with adhesive tape (Fig. 2-4, Fig. 2-5).
- [4.] Use a punch to mark screw holes position as shown on the template (Fig. 2-6).
- [5.] Reverse template ⑩ and mark screw holes positions by using hole made during step [4] in the template (Fig. 2-7, Fig. 2-8).
- [6.] Similarly mark position of screw hole for all other cabinet modules.
- [7.] Using binding screws ⑥, fasten tightly lower rail ② to the first module, in the position marked in the previous steps.
* **Important: Make sure that the lower rail ② is firmly fixed and that it can rotate 90 degrees.**
- [8.] Insert connecting pin ⑧ in the hole on the side of lower rail ② (Fig. 2-10).
- [9.] Proceed with installation of the lower rail immediately adjacent to the one installed in [7], by matching the pin ⑧ inserted in [8] with the hole of the new lower rail. Use binding screws ⑥ to fasten the new lower rail.
- [10.] Repeat operations [8] and [9] until all lower rails are installed.
* **Important: Do not insert any connecting pin ⑧ at either end assembled line of lower rails.**
- [11.] Firmly fix lower end caps L ⑬ and R ⑭ at the appropriate end of the lower rail assembly (Fig. 2-9).

STEP 2: Upper rail installation



Portion to be used for fixing upper rail

Fig. 3-1

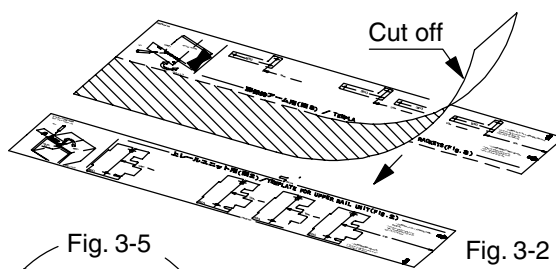

Fig. 3-2

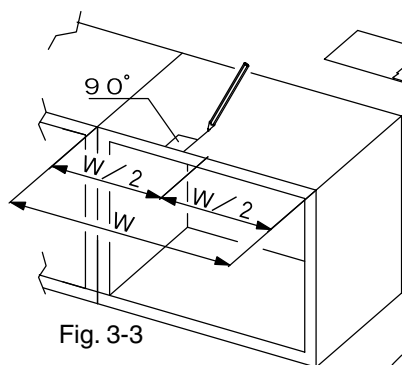

Fig. 3-3

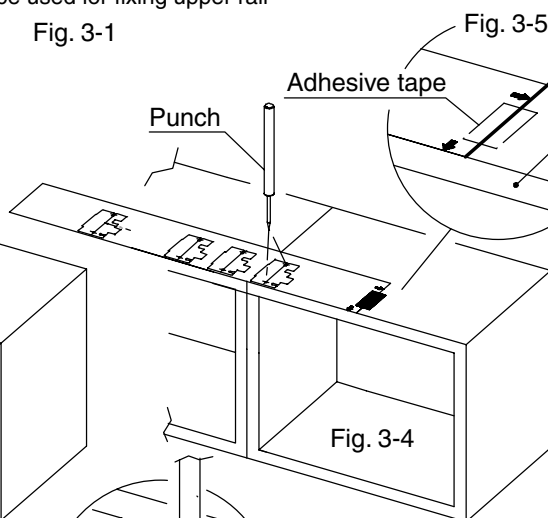

Fig. 3-4

Mark the positions of holes.

Fig. 3-6

Mark the positions of holes by using holes made on template.

Fig. 3-8

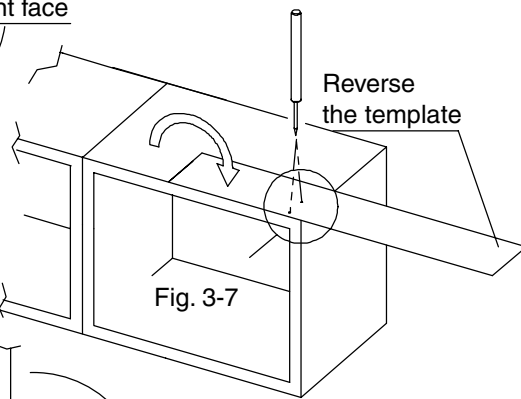

Fig. 3-7

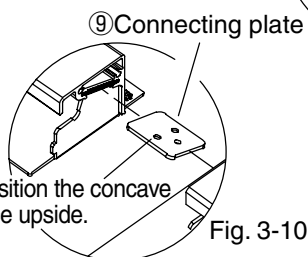

Fig. 3-10

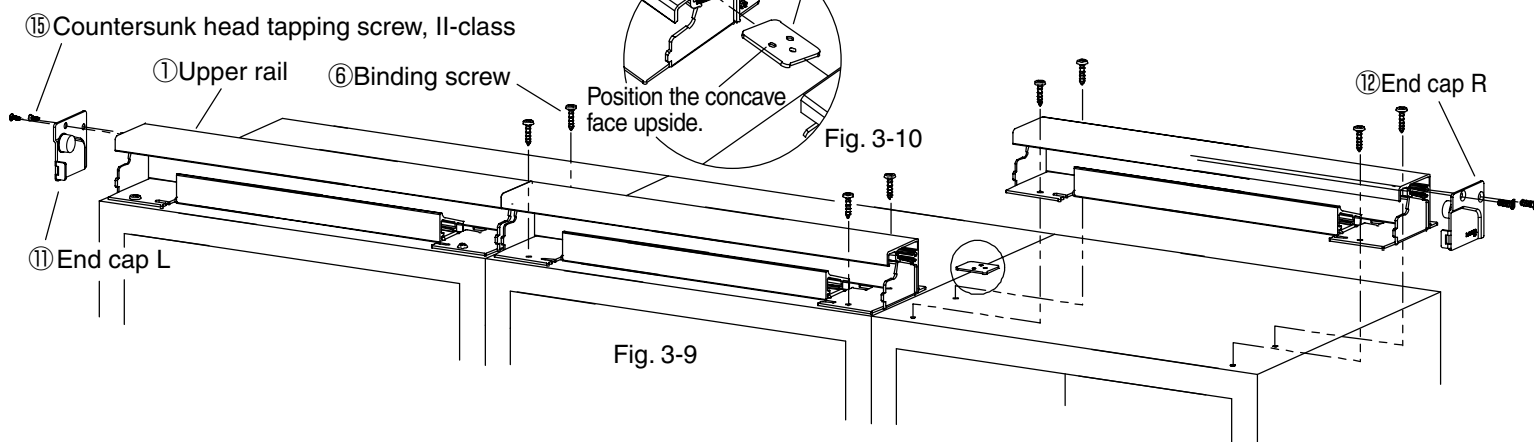
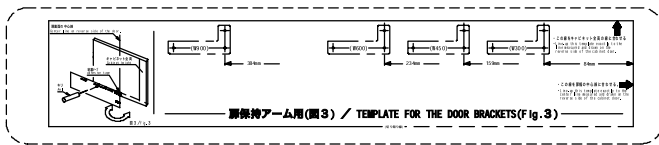

Fig. 3-9

- [1.] Cut off upper rail installation template ⑩ along perforated line (Fig. 3-1, Fig. 3-2)
- [2.] Draw the width cabinet center line on the top of the cabinet (Fig. 3-3)
- [3.] Align the edges of template ⑩ with the center line marked in [2] and the front edge of the cabinet. Secure template with adhesive tape (Fig. 3-4, Fig. 3-5).
- [4.] Use a punch to mark screw holes position as shown on the template (Fig. 3-6).
- [5.] Reverse template ⑩ and mark screw holes positions by using hole made during step [4] in the template (Fig. 3-7, Fig. 3-8).
- [6.] Similarly mark position of screw hole for all other cabinet modules.
- [7.] Using binding screws ⑥, fasten tightly upper rail ① to the first module, in the position marked in the previous steps.
* **Important: Make sure that the upper rail ① is firmly fixed.**
- [8.] Insert half of the connecting plate ⑨ in the slot inside the upper rail ① (Fig. 3-10).
- [9.] Proceed with installation of the upper rail immediately adjacent to the one installed in [7], by matching the plate ⑨ inserted in [8] with the slot in the new upper rail. Use binding screws ⑥ to fasten the new upper rail.
- [10.] Repeat operations [8] and [9] until all upper rails are installed.
* **Important: Do not insert any connecting plate ⑨ at either end assembled line of upper rails.**
- [11.] Firmly secure end covers L ⑪ and R ⑫ with tapping screws ⑮. (Fig. 3-9).

STEP 3: Door fittings installation



Portion to be used for fastening door brackets
Fig.4-1

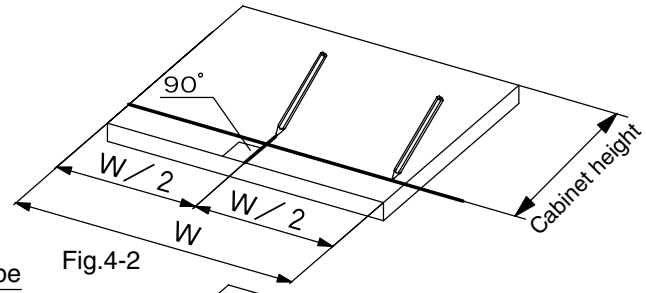

Fig.4-2

Align the edges of template with lines.

Adhesive tape

Punch

Fig.4-5

Reverse the template.

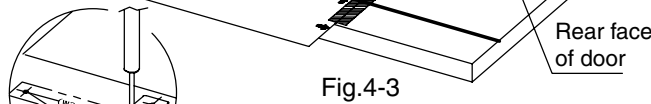

Fig.4-3

Rear face of door

Fig.4-6

Mark the positions of holes by using holes made on template.

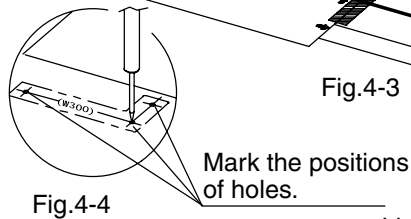

Fig.4-4

Mark the positions of holes.

Line for cabinet height

③ Door bracket

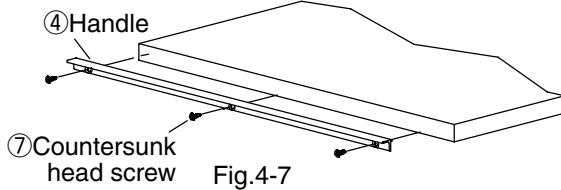

Fig.4-7

④ Handle

⑦ Countersunk head screw

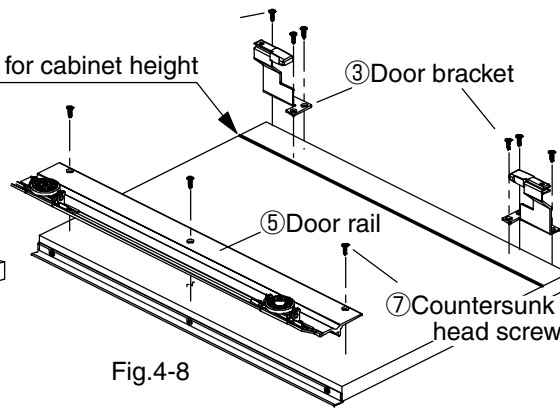

Fig.4-8

⑤ Door rail

⑦ Countersunk head screw

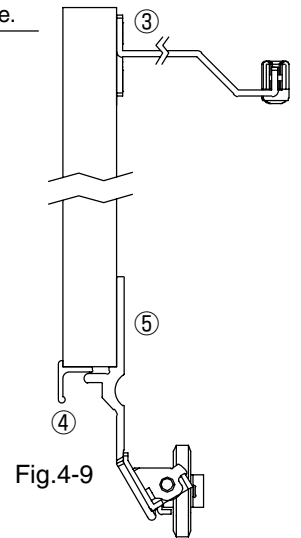
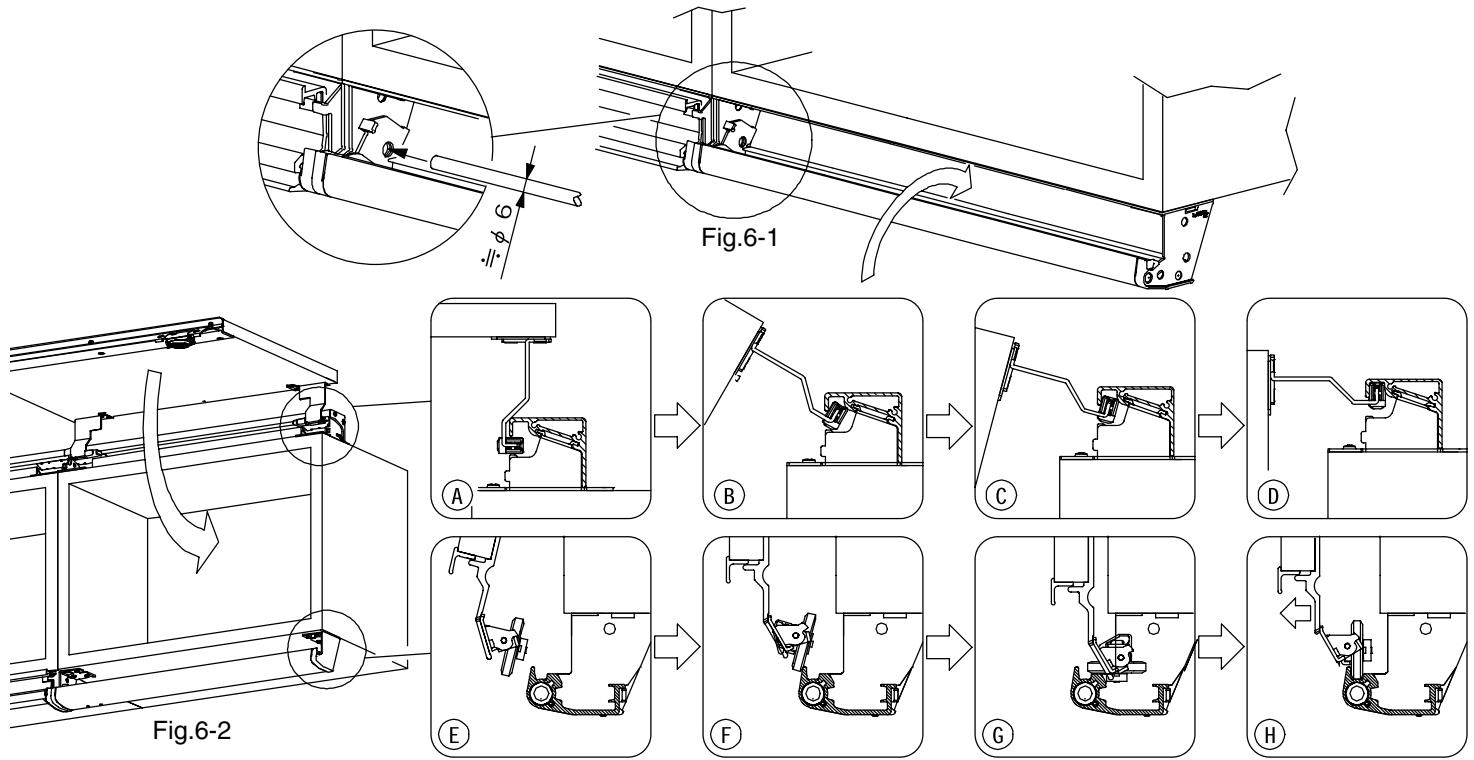

Fig.4-9

- [1.] Draw a line indicating the cabinet height and then a perpendicular one in the middle of the door width (Fig. 4-2)
- [2.] Align the edges of template ⑩ with the lines marked in [1]. Secure template with adhesive tape (Fig. 4-3).
- [3.] Use a punch to mark screw holes position as shown on the template (Fig. 4-4).
- [4.] Reverse template ⑩ and mark screw holes positions by using hole made during step [3] in the template (Fig. 4-5, Fig. 4-6).
- [5.] Fasten door handle ④ facing towards the outside with screw ⑦ (Fig. 4-7, Fig. 4-9)
- [6.] Fasten door sliding profile ⑤ on the back of each door using screws ⑦ (Fig. 4-8, Fig. 4-9)
- [7.] Fasten door brackets ③ at the position marked in [3] and [4], by using screws ⑦ (Fig. 4-8).
- [8.] Repeat steps [1] to [7] for all other doors.

*** Important: Be careful not to bend door brackets ③ during installation of the door fittings.**

STEP 4: Doors installation



- [1.] Rotate lower rail ② 90 degrees to its closed position so that the hole on the side of the rail and the side brackets are lined up. To hold it in that position, insert a screwdriver or similar tool (ϕ 6mm) in the hole (Fig. 6-1)
- [2.] Hold the door horizontally and insert the door brackets ③ in the upper rail ① (Fig. 6-2A). Slowly bring the door down to its vertical position ((Fig. 6-2B to D).
- [3.] When bringing the door down, insert the rollers into the lower rail ② and then pull back the door slightly so that the rollers slide in the front channel (Fig. 6-2E to H).
- [4.] Slide the door to the furthest available module and close it.
*** Important: When closing the door immediately adjacent to the one where the doors are inserted, make sure that the screwdriver inserted in [1] does not obstruct the rotation of the lower rail.**
- [5.] Repeat steps [2] to [4] for all remaining doors. For the last door, slide it to the adjoining module and proceed to step [6].
- [6.] Remove the screwdriver or tool inserted in [1] and allow the lower rail ② to return to its original position. Slide the last door to that position and close the door.

⚠ Caution

1. When inserting the screwdriver in step [1], make sure not use too big a tool as it may prove hard to remove and/or may damage the rail.
2. When lowering the doors in step [2], should you feel a resistance, make sure that the bracket ③ are well inserted in the upper rail ① and restart the operation. Never forcibly lower a door as this would bend the bracket or damage the rail.
3. Should the screwdriver holding the lower rail ② in step [1] fall at any time during the installation, immediately remove any doors that is not properly installed and start again.

In case there is enough space on one side of the cabinet, it is easier to simply remove both end cap and rail cover of that side and insert each door through the side of the cabinet (Fig. 6-3, Fig. 6-4 and Fig. 6-5).

*** Important: Do not forget to replace and secure both the end cap and rail cover or doors may fall from the rail during operation.**

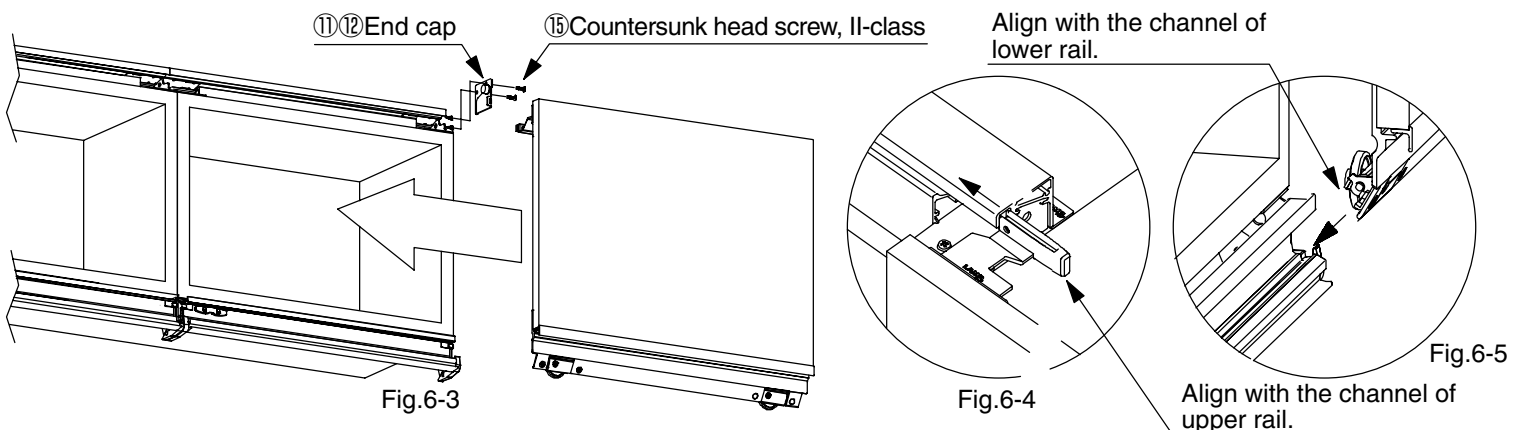

STEP 5: Adjustments

* Important: We recommend that both outside doors be adjusted first with regards to the sides of the cabinet. They will then serve as reference for other doors.

[Skew adjustment]

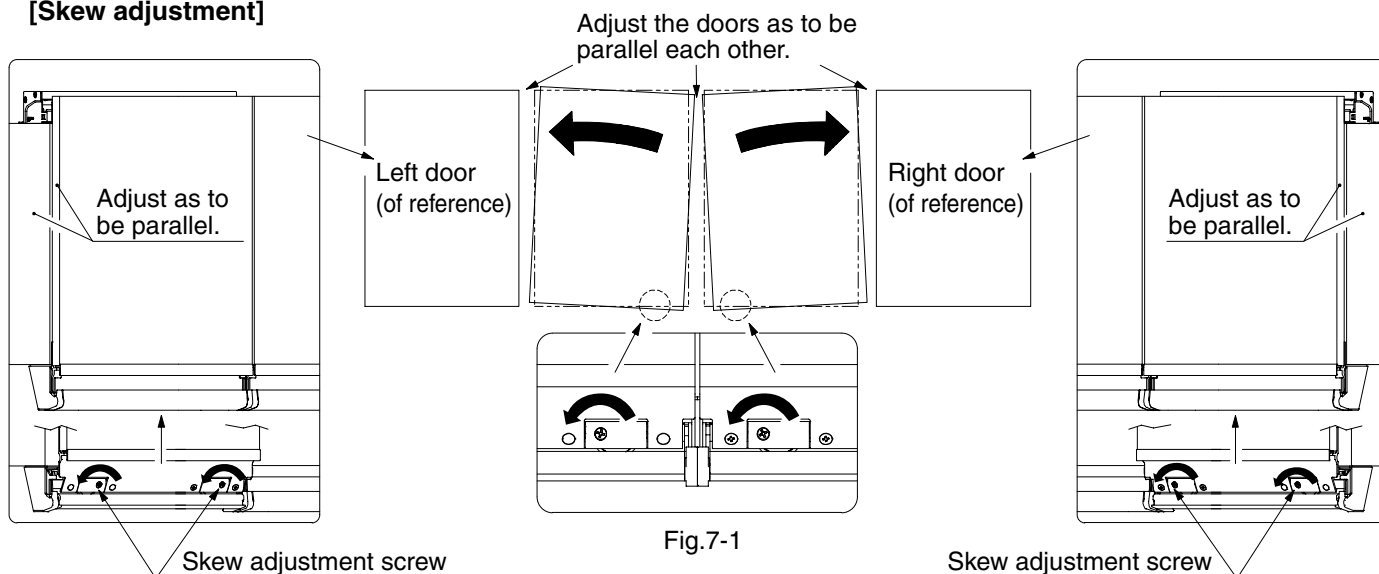

- [1.] Pull the door to its open position to show skew adjustment screws (Fig. 7-1).
- [2.] Turn either the right-hand or left-hand screw counter-clockwise, depending on the adjustment direction required (Fig. 7-1).
- [3.] Push the door back to its closed position.
- [4.] Repeat operations [1] to [3] with the door immediately next to the previous one and ensure that both doors are parallel.

⚠ Caution

The factory setting for the skew adjustment screws is fully turned clockwise. The maximum adjustment range is two turns counter-clockwise, corresponding to a height adjustment of 2mm. Do not attempt to turn screws clockwise when starting the adjustment and to not exceed the adjustment range as this may damage the assembly.

[Adjustment of the gap between doors]

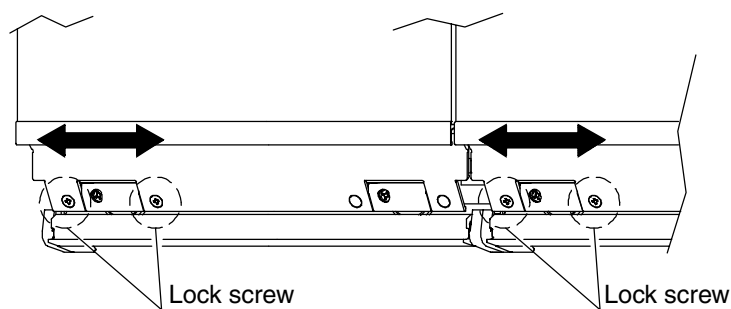
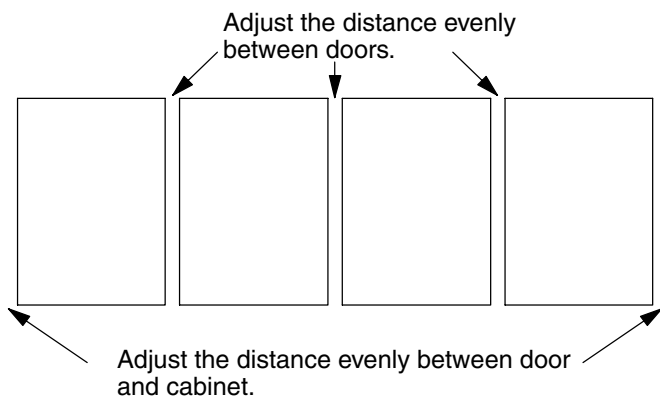

- [1.] Pull the door to its open position to show the locking screws (Fig. 7-3)
- [2.] Loosen both locking screws by turning them half a turn counter-clockwise.
- [3.] Slide the door manually to the correct position. Door position can be adjustment 2mm in both directions.
- [4.] Fasten locking screws.
- [5.] Repeat procedures [1] to [4] for all doors.

⚠ Caution

1. Do not loosen locking screws excessively for risk of disassembly of the sliding profile.
2. The recommended tightening torque for the locking screws is 1.5 ~ 2.0N·m

■ Removal procedure:

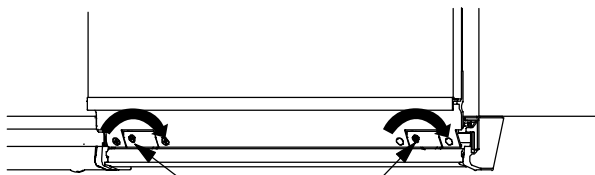

Skew adjustment screw
Fig.8-1

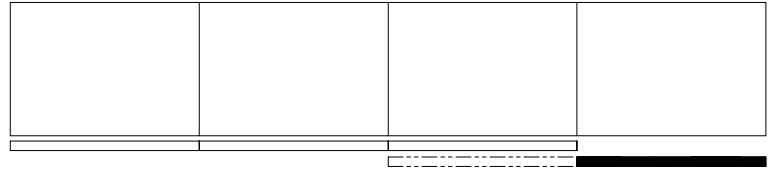

Fig.8-2

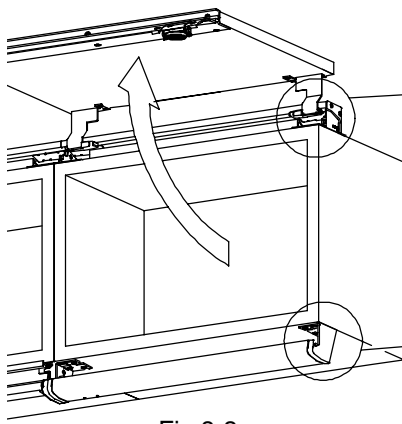
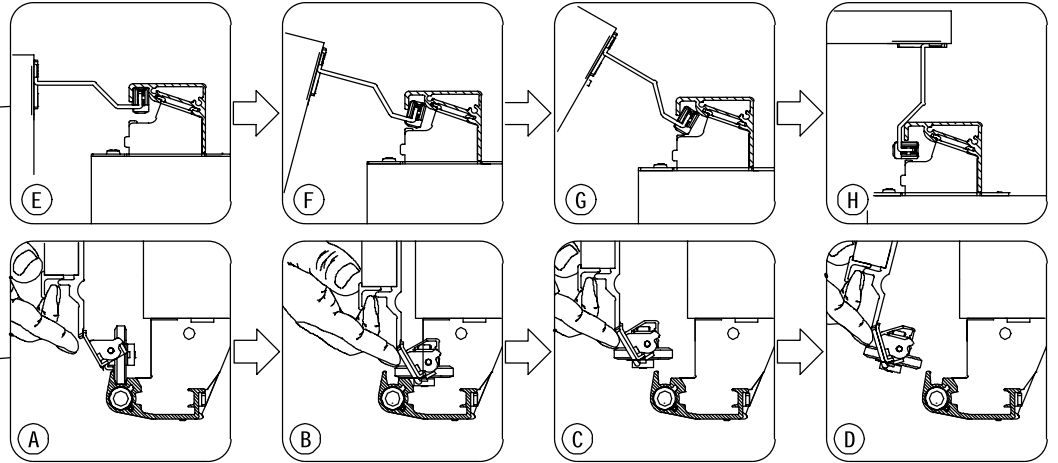

Fig.8-3



- [1.] Pull the door to its open position and turn both skew adjustment screws clockwise completely (Fig. 8-1).
- [2.] Slide the door sideways, and secure the lower rail ② in its closed position as shown on page 8 (Fig. 6-1)
- [3.] Slide the door back to its original position.
- [4.] While lifting the door slightly, push the bottom forward so that the rollers fold horizontally (Fig. 8-3 A-B).
- [5.] While keeping the rollers horizontal, pull the bottom of the door away from the rail (Fig. 8-3 C-D).
- [6.] Tilt the door all the way up so that it is perpendicular with the upper rail ① (Fig. 8-3 E to H).
- [7.] Remove the door completely by sliding the door brackets ③ out of the upper rail ① .
- [8.] Repeat procedures [4] to [7] for each door after sliding them to the position of the first door.

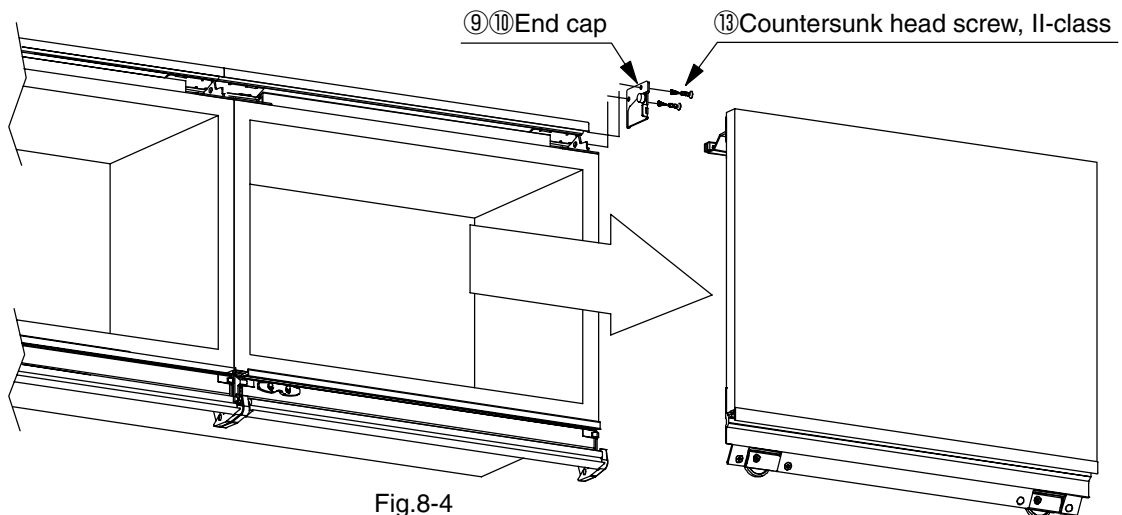

Fig.8-4

In case there is enough space on one side of the cabinet, it is easier to simply remove both end cap and rail cover of that side and slide each door out through the side of the cabinet (Fig. 8-4).

* **Important:** pull the doors as straight as possible in order to avoid excessive stress on the door brackets ③ .

■ Troubleshooting:

Case	Possible cause		Check	Solution	Page
Doors do not close or close incompletely	Bottom of cabinet is obstructing the rotation of lower rail ② .	⇒	Check the bottom of the cabinet for obvious sag.	Sag should be less than 2mm. Replace cabinet bottom if necessary.	
	Doors edges hit each other.	⇒	Check if door width is within the specifications.	Replace with appropriately sized door.	2
			Check the distance between the doors.	Adjust the gap between the doors.	9
	Washers on the door bracket ③ are obstructing the closing of the doors (Fig. 9-1).	⇒	Check position of both upper rail ① and lower rail ② .	Reinstall both rails in their proper position.	3,5,6
			Check rectangularity of the cabinet.	Replace cabinet module with a rectangular one.	4
			Check rectangularity of the doors.	Replace door with a rectangular one.	4
	Door comes into contact with the front of the cabinet.	⇒	Check position of both upper rail ① and lower rail ② .	Reinstall both rails in the proper position.	5,6
			Check if the door is in front of a storage position (Fig. 9-6).	Move the door to the proper position before attempting to close it.	-
			Check if door weight is within the specifications.	Replace with door of appropriate weight.	2
	Doors do not slide (or not smoothly)	Door bracket ③ hits the inside of the upper rail ① (Fig. 9-2)	⇒	Check that both upper rail ① and lower rail ② are tightly fastened.	Screw both rails tightly.
Check door warp.				Warp should be less than 2mm. Replace the door if necessary.	4
Friction between the door bracket ③ and the inner top of the upper rail ① (Fig. 9-3).		⇒	Check the fixing position of the door brackets ③ .	Reinstall door brackets in their proper position.	3,7
Door bracket ③ scratches the top of other doors (Fig. 9-4).		⇒	Check if door height is within the specifications.	Replace with door of appropriate height.	2
	Check the fixing position of the door brackets ③ .		Reinstall door brackets in their proper position.	3,7	
Sliding noise	Roller is not turning properly (Fig. 9-5).	⇒	Check to see if roller is dirty.	Remove any dirt from the roller.	-
			Check to see if any foreign matter is caught in the rail.	Clean up the rail.	-

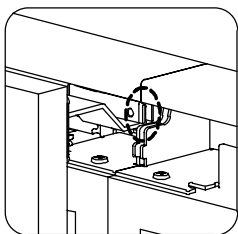

Fig.9-1

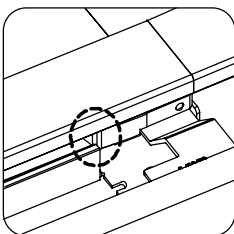

Fig.9-2

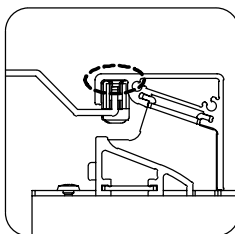

Fig.9-3

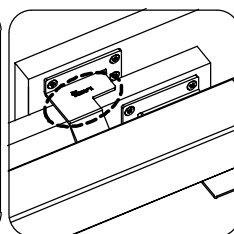

Fig.9-4

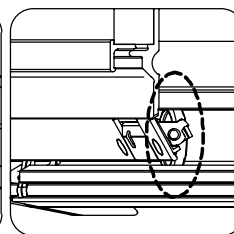

Fig.9-5

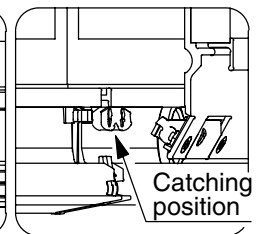

Fig.9-6

