

# LAMP<sup>®</sup> MonoFlat FAD<sup>®</sup> FAD-54、FAD-54L

Video Link



## Aluminum Frame Type Instruction Manual

Thank you for selecting our product. Before starting installation, please read this manual thoroughly to ensure correct installation. Please keep this manual at hand for future reference.

### ■ About this product.

Lateral swing mechanism hardware that can be installed in narrow spaces where a normally hinged door may not fit.  
Ideal for tight from space applications

- There is no need of embedding a rail on the floor.
- It is possible to adjust the door vertically (-3 to +7 mm), horizontally ( $\pm 7$  mm), as well as in depth and parallel.  
\*In order to make it possible to adjust, make sure that the shelf board can be detached for access.

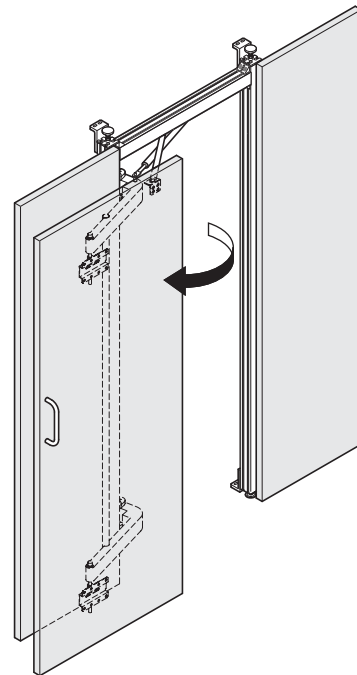

### ■ For your safe work and correct installation.

#### Meaning of symbols



#### **WARNING:** If these warnings are not followed, it may result in death or serious injury.

- ❗ This (sliding door system) should be installed by an experienced person who has correct knowledge. If the system is not installed correctly, the door will not operate smoothly, and or may cause injury.
- ❗ It is necessary to manufacture the frame with sufficient strength so it endures the weight of the door and impact shocks upon opening/closing the door. Also make sure to only use the designated screws and to fasten them firmly. A frame with poor strength or loose screws might result in improper and slower movement of the door. In the worst case, the door might drop down and cause injury.
- ⊘ Do not try to use this product for any other purposes than originally intended for. Do not use the parts for applications that are out of specification.
- ⊘ Do not disassemble nor modify any parts other than those described in this document.

#### **Caution** If these cautions are not followed, it may result in injury or damage.

- ❗ This product is a part for cabinets. After installation, make sure to test the finished product thoroughly to ensure that it is well-functioning and safe.
- ❗ Make sure to follow the designated measurements and specifications as well as horizontal and vertical angles. Make sure that frame and door are not warped nor bent, since it may affect the movement of the door.
- ❗ If cutting any parts, make sure to remove any burr before installation.
- ❗ Make sure to test the screws for slack at regular intervals (one month from first usage, half year and then one time every year is recommended).

### ■ Notes on works.

#### Handling of product

- The door is not supplied.
- After unpacking the product, check for damages on the parts.



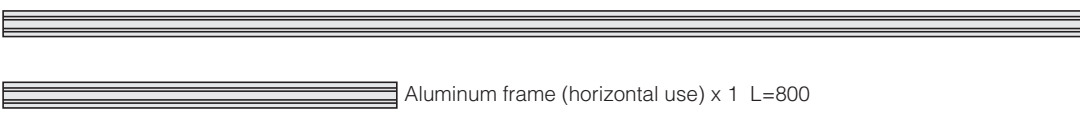

## ● Specifications

Frame width	From 750 mm to 800 mm* * If the overlay distance on both sides of side plate is 25 mm, the door width should be 800 to 850 mm.	Door thickness	From 24 to 38 mm
		Door weight	Max. 35 kg
Door height	Max. 2380 mm [2980 mm]	The size in [ ] applies to the FAD-54L.	

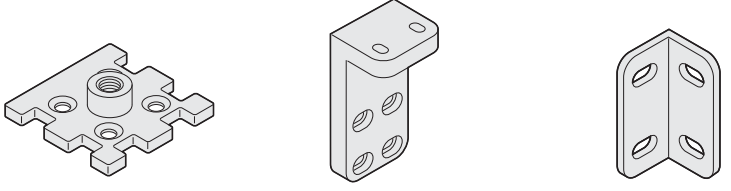
## ● Description of parts

**1**  Aluminum frame (vertical use) x 2 L=2300 [2900]  
Aluminum frame (horizontal use) x 1 L=800

**2** 





Supplied Screw		Q'ty
Square nut M6		28
Hexagon socket head cap screw M6x12		28
Hexagon socket head cap screw M6x16		8
Flat washer		36
Countersunk self-tapping screw 4.5x15		16

Adjuster base x 4      Bracket for Aluminum frame x 4      Angle joint x 6

**3** Support arm x 1  
Upper arm (w/ stopper) x 1  
Lower arm x 1



 Crank bracket

 Clear cushion rubber x 1 + 1 (spare)

Supplied (for assembling arm) Screw		Q'ty
Hexagon socket head cap screw M6x12		2
Spring washer		2
Cross-recessed blind self-tapping screw 4.5 x 20		4
Square nut M6(No need for this application)		2

**4**  Arm connecting pipe x 1  
Pipe length=1990 [2600]



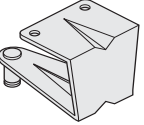

 Pipe clamp x 1

Supplied Screw		Q'ty
Hexagon socket head cap screw M6x35		4
Flat washer		4



**5**  Gas spring holder x 1

 Screw pin x 1

 Conical springwasher x 1

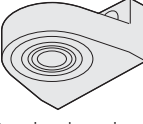
Supplied Screw		Q'ty
Hexagon socket head cap screw M6x12		2
Spring washer		2
Flat washer		2
E-ring		2
Square nut M6(No need for this application)		2

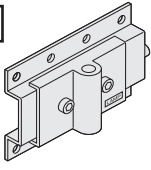

**6**  Bearing housing x 4

Supplied Screw		Q'ty
Hexagon socket head cap screw M6x12		8
Spring washer		8
Square nut M6(No need for this application)		8

**7**  Positioning unit x 2

Supplied Screw		Q'ty
Cross-recessed blind self-tapping screw 4.5 x 20		16

**8** Parts to assemble support arm **3** and positioning unit **7**.

Supplied Screw		Q'ty
Hexagon head bolt M10x150		2
Hexagon nut M10		2
Flat washer 10		2

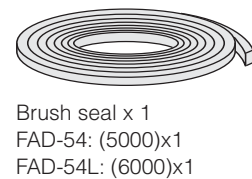
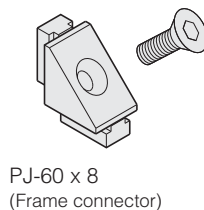
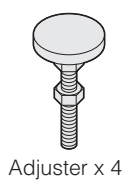

## ■ Tools used

- Anchor plugs and screws
- Saw to cut an aluminum pipe
- Support(for door hanging)
- Tape for tentative hold
- Phillips screwdriver No. 2
- Wrench 10, 16 mm
- Hex key 5 mm
- E-type retaining ring mounter

# 1

# Assembling Aluminum Frames

① When assembling the aluminum frames, work on the floor, and orient the surface of the aluminum frame without groove downward.

## Assembling aluminum frame

The figures shown in this manual are applicable to the left-side-opening type door (left-hinged type). For the right-side-opening type (right-hinged type), install the parts identically but reversed.

Symbols from ① to ⑧ shown in the figure indicate the locations described below.

### ① Cutting aluminum frame (vertical use)

Cut the "Aluminum frame (vertical use)" to the length "Ceiling height - 100mm". The maximum ceiling height is 2400 mm [3000 mm].

Ex) If the ceiling height is 2300 mm, the frame length is 2200 mm.

### ② Cutting aluminum frame (horizontal use)

Cut the "Aluminum frame (horizontal use)" to the setup width (from 750 to 800 mm).

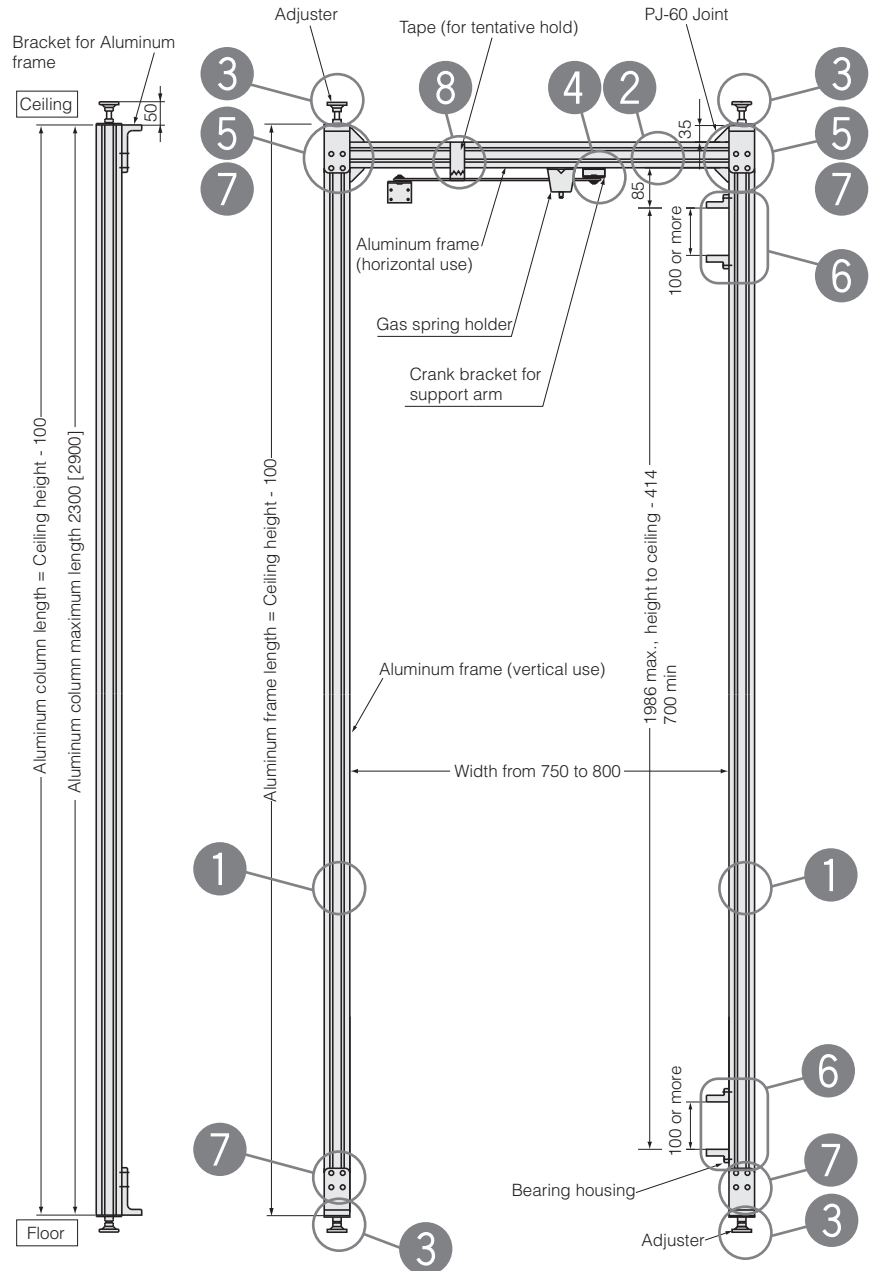

The size in [ ] applies to the FAD-54L.

### ③ Installing the adjuster

Install the "Adjuster base" to the both ends of the "Aluminum frame vertical column" with the attached four countersunk head screws.

Then, screw the "Adjuster" into the "Adjuster base". Height of the adjuster should be 50 mm from the ceiling surface. Fully screw in the adjuster on the floor side.

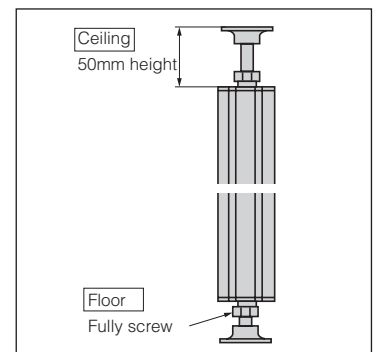
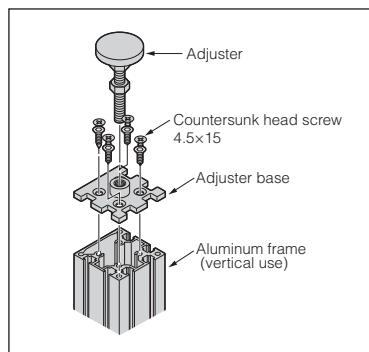

## 4 Installing bracket

Temporarily fix the “Crank bracket for support arm” and “Gas spring holder” to the “Aluminum frame (horizontal use)”.

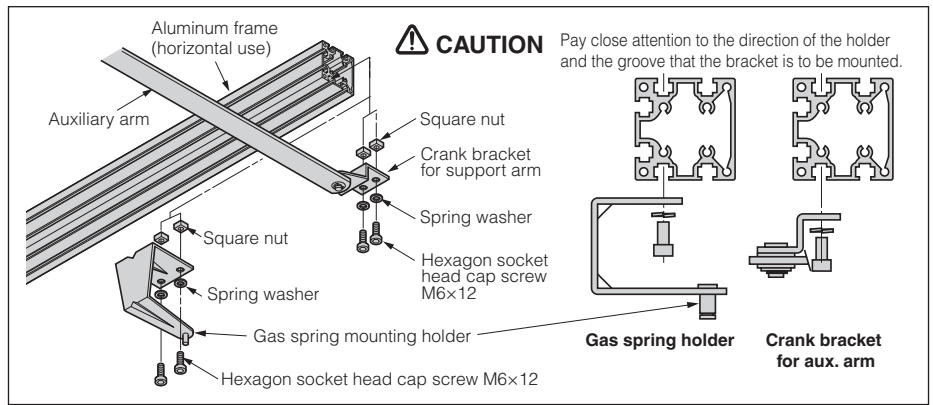

## 5 Assembling aluminum frames

Completely assemble the “Aluminum frame (vertical use)” and “Aluminum frame (horizontal use)” into a gate with “PJ-60 (frame connector)”.

- 1 Fit the inner joints into the gaps of the aluminum frame.
- 2 Put the outer joints onto the inner joints.
- 3 Tighten with the screws.

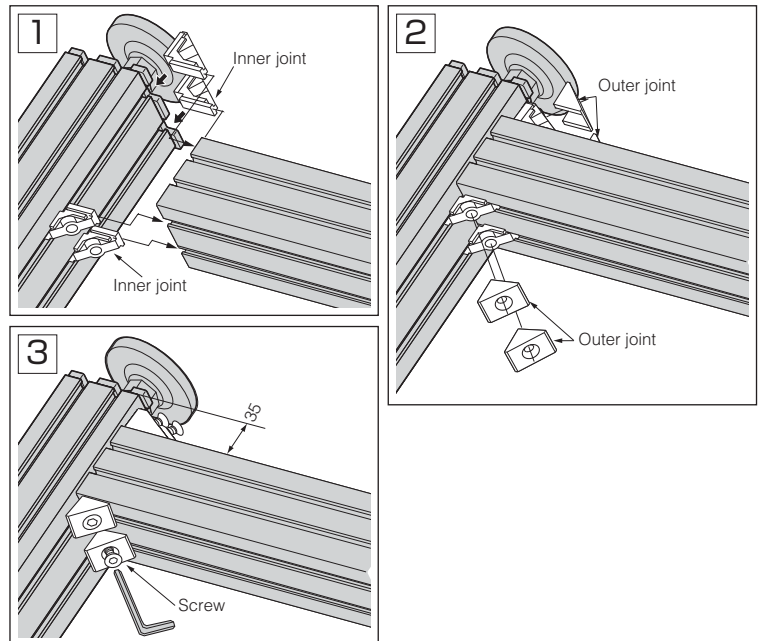

**!** When assembling, pay close attention to prevent any gap in the joint of the aluminum frames.

## 6 Fixed bearing housing

Fix the “Bearing housings” with the screws as shown in the figure below. For the mounting dimensions, see the figure shown on P.3. Temporarily fix the two housings located to the inner side of the upper and lower sets of the bearing housing.

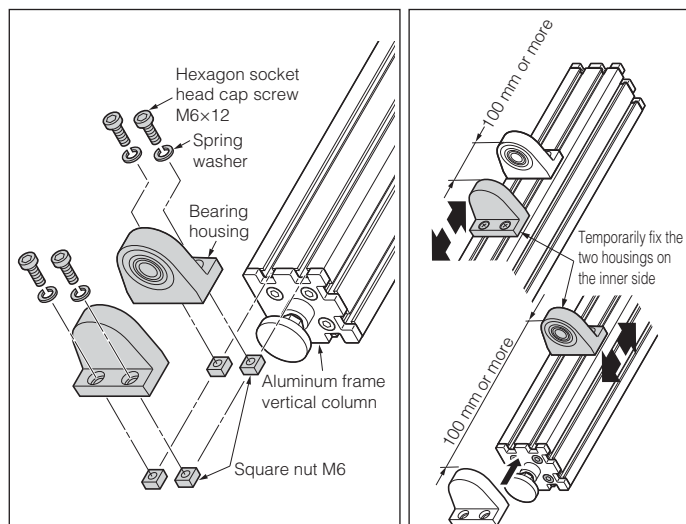

## 7 Installing aluminum frame fixing bracket

Temporarily fix the “Column fixing bracket” with the attached screws to the location shown on the figure on P.3 (upper and lower ends of aluminum frame).

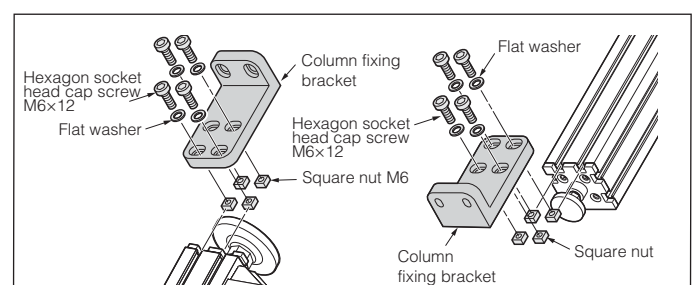

## 8 Temporary fixing of auxiliary arm

Temporarily fix the “Auxiliary arm” with tape to the aluminum frame (horizontal use) so that it is not moved. (Tape is not enclosed.)

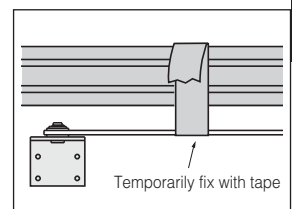

# 2 Fixing Aluminum Frame

## 1 Fixing aluminum frame to installing location

Temporarily fix the assembled aluminum frame with facing the surface without gap to the front side (door side) and extending the ceiling side adjuster.

Then, fix the "Aluminum frame (vertical use)" with the "Alu-frame fixing bracket" to the ceiling surface and the floor surface with the screws. **!** 1

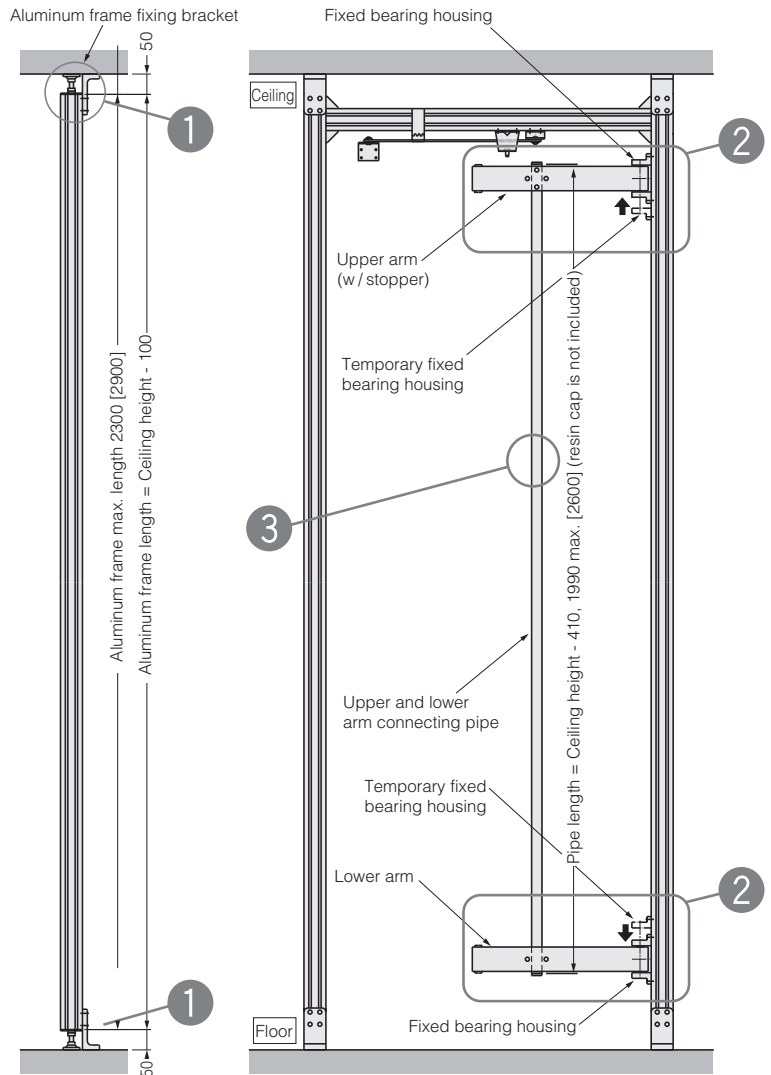
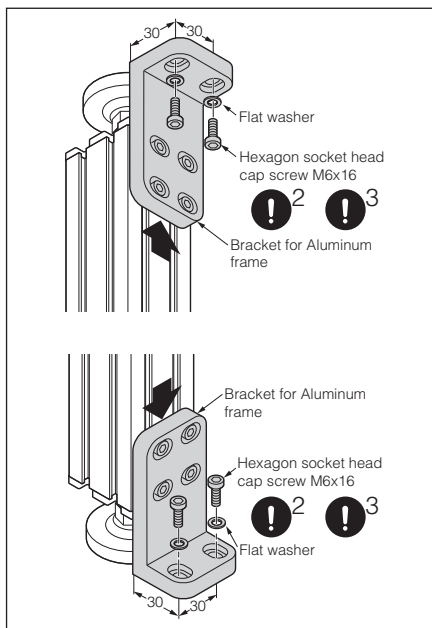
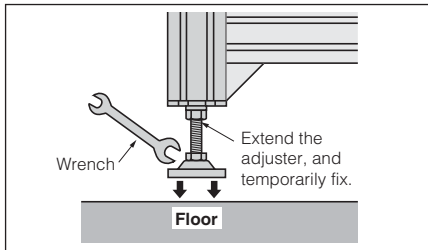

The size in [ ] applies to the FAD-54L.

- !** 1 When fixing the "Aluminum frame (vertical use) with the (Alu-frame) fixing bracket", vertically fix the aluminum frame (vertical use) with a use of leveler or bubble leveler.
- !** 2 When installing the aluminum frame onto the concrete surface, put a M6 anchor nut, and fix with screws in 16 mm or more length.
- !** 3 When installing the aluminum frame onto the wooden or plywood surface, put a M6 insert nut, and fix with screws in 16 mm or more length or self-tapping screw or wooden screw of nominal size from 5 to 6. Use the screw with length that enough strength can be secured. (No anchor nut, insert nut, self-tapping screw, or wooden screw is attached.)

## 2 Installing upper and lower arms

Insert the shaft of the "Upper arm (w/ stopper)" into the upper "Bearing housing". Insert the temporarily fixed "Bearing housing" into the lower shaft of the arm, and securely fix. Insert the "Lower arm" in a same manner from the direction reverse to the above, and fix.

! Ensure that all the screws are securely tightened.

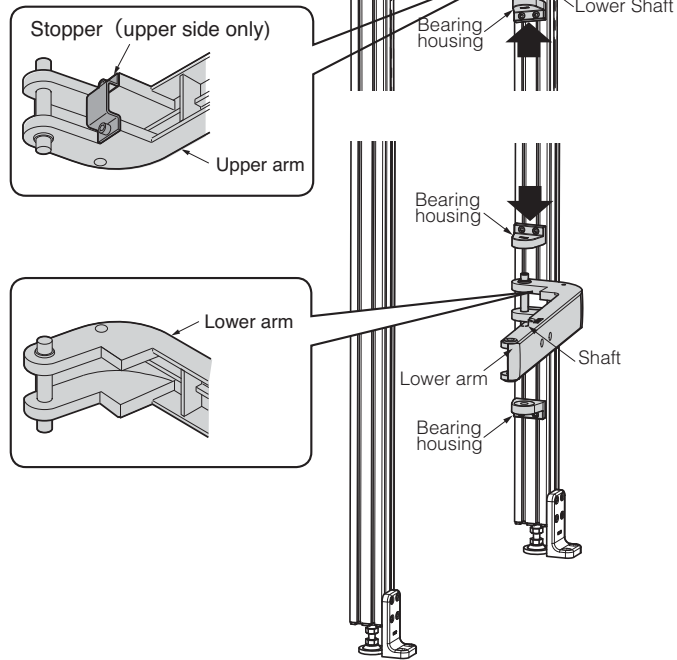

## 3 Installing Arm connecting pipe

(1) Cut the Arm connecting pipe" as shown on the figure below.

(Cut the pipe end without the clamp.)

(2) Remove burrs around the cutting edge to prevent injury and enable smooth insertion of the cap.

(3) Replace the cap on the cut end.

(4) Attach the Connection pipe to the cutout part on both arms and fix it with the provided screws and flat washers.

(5) Torque the screws step by step, in a criss-cross pattern, to prevent torsion of the pipe.

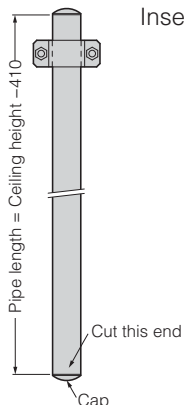

Insert the cap into the cut end.

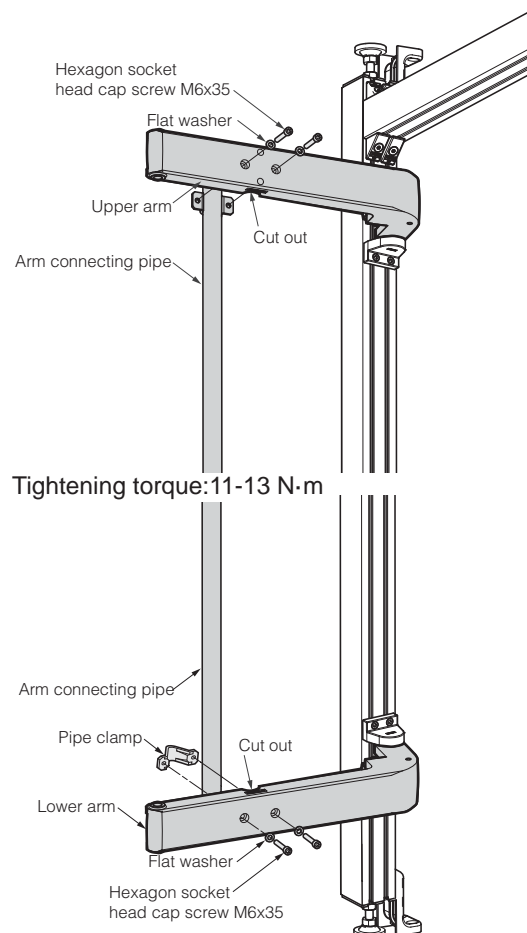

# 3 Installing Gas Spring

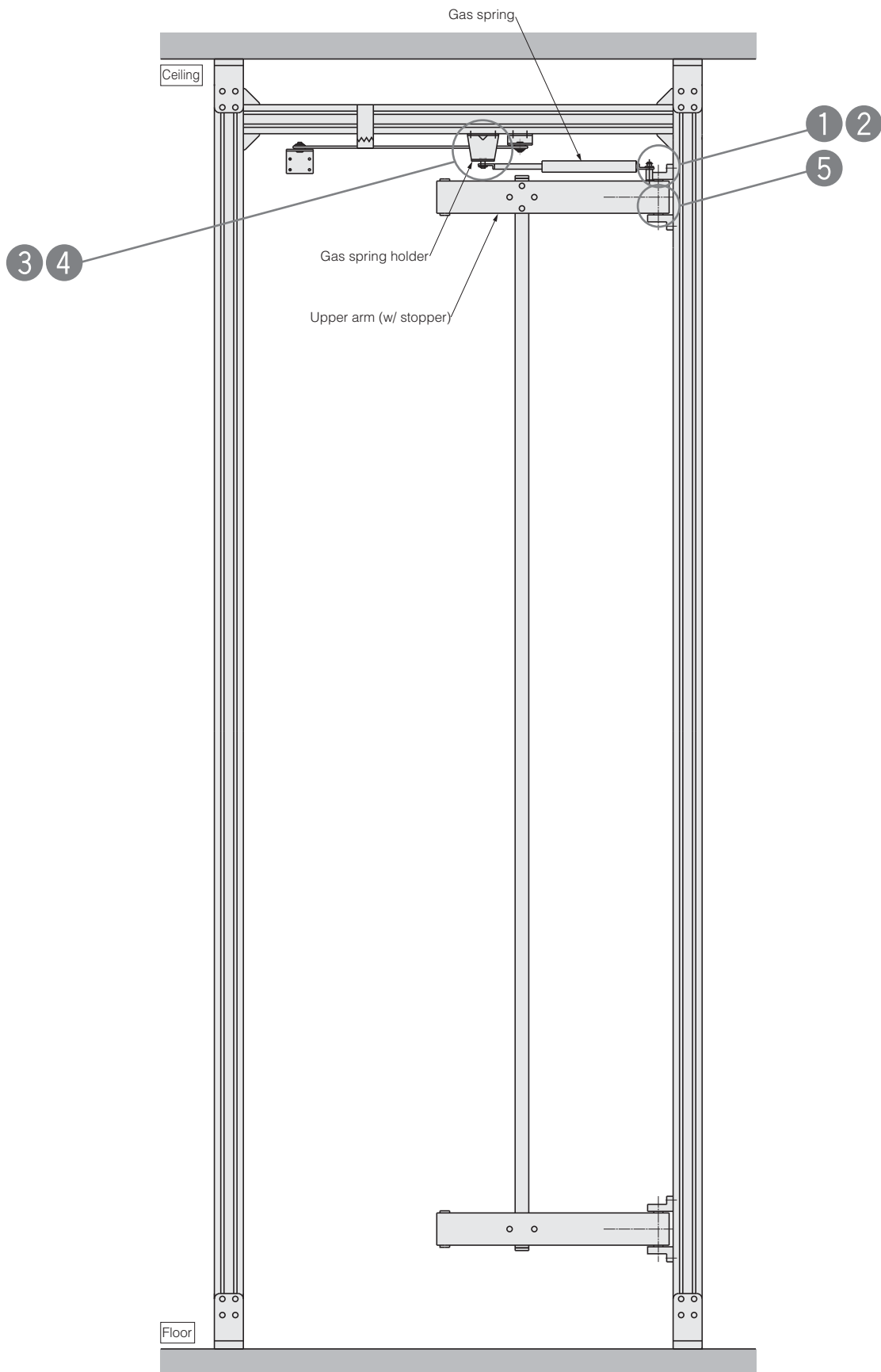



## 1 Installing screw pin

Tighten the Screw pin firmly into the tapped hole on the top face of the Upper arm.(Use a wrench (10).)

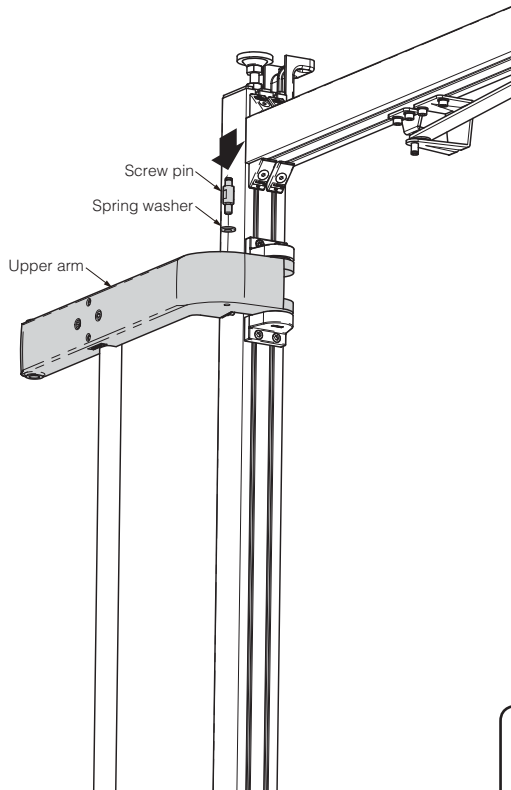

## 2 Installing the gas spring (arm side)

Move the Upper arm to the full opening position where the stopper touches the vertical frame, then assemble the Gas spring to the Screw pin as shown in the below figure.

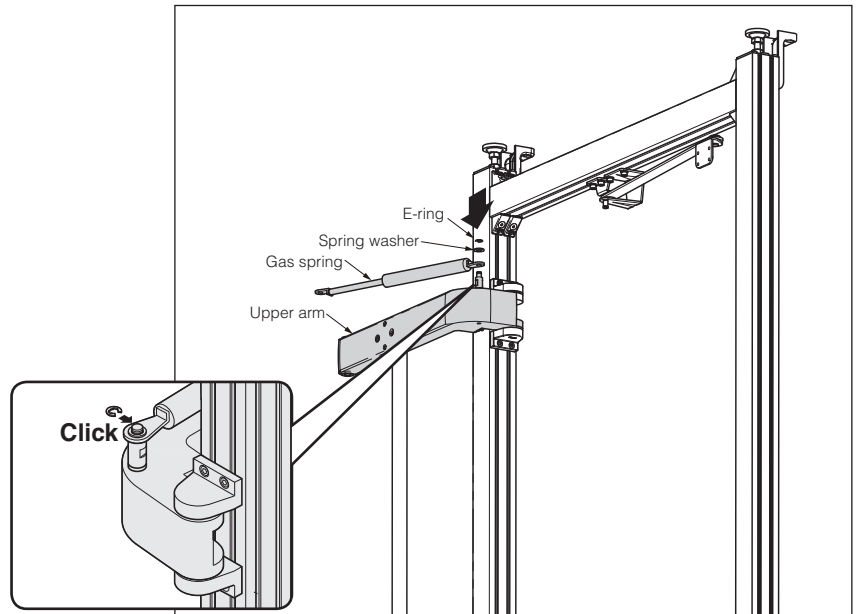
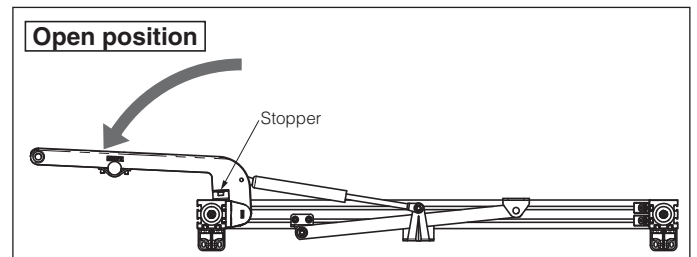

## 3 Fixing Gas spring (top frame)

Loosen the screws on the Gas spring holder a little. Assemble the Gas spring to the Screw pin as shown in the below figure.

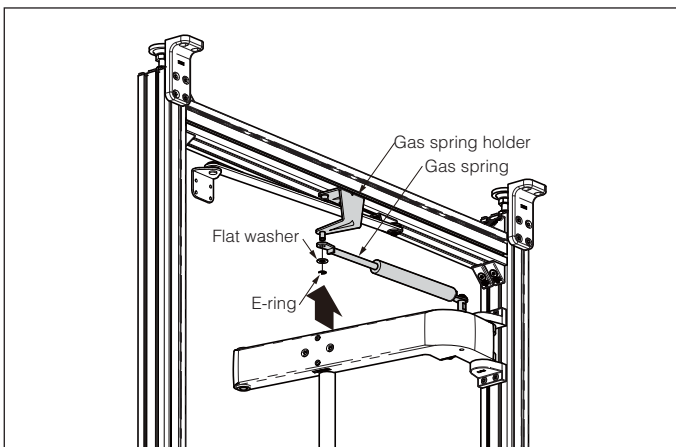

## 4 Fixing Gas spring holder

With Upper arm at the full opened position where the stopper touches the vertical frame, tighten the screws on the Gas spring holder firmly.

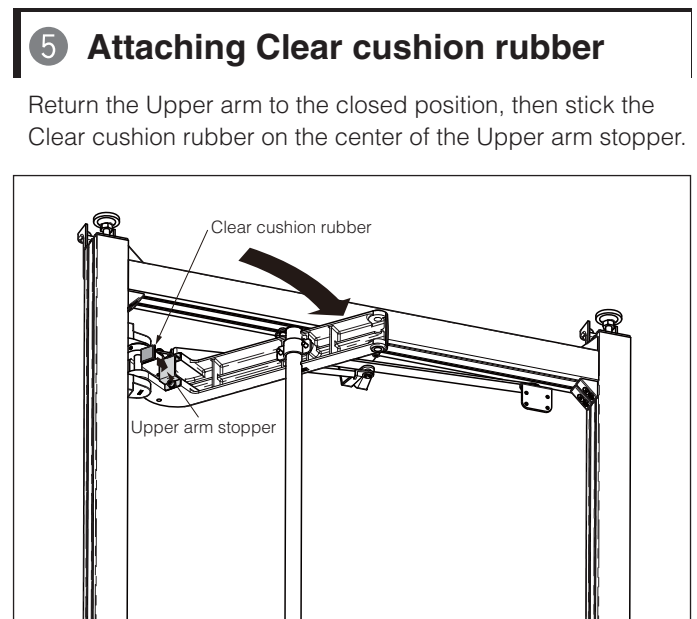

## 5 Attaching Clear cushion rubber

Return the Upper arm to the closed position, then stick the Clear cushion rubber on the center of the Upper arm stopper.



# 4 Installing Parts to Door

## 1 Fixing Positioning unit

Mount the Positioning unit on the rear face of the door with the provided screws so that the LAMP logo can be seen properly.

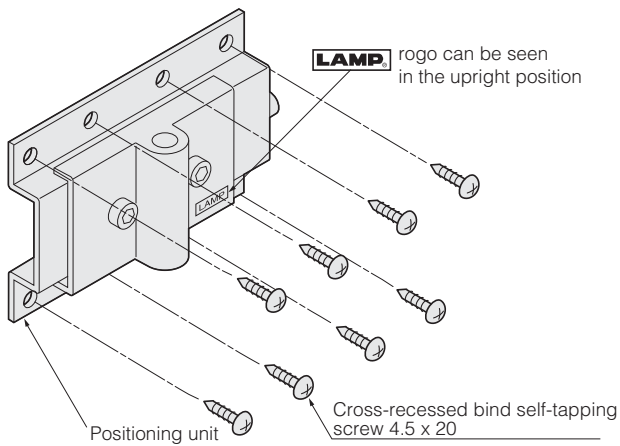

## CAUTION

Set core material of which strength is enough for secure tightening of self-tapping screws to the locations that parts are to be installed.

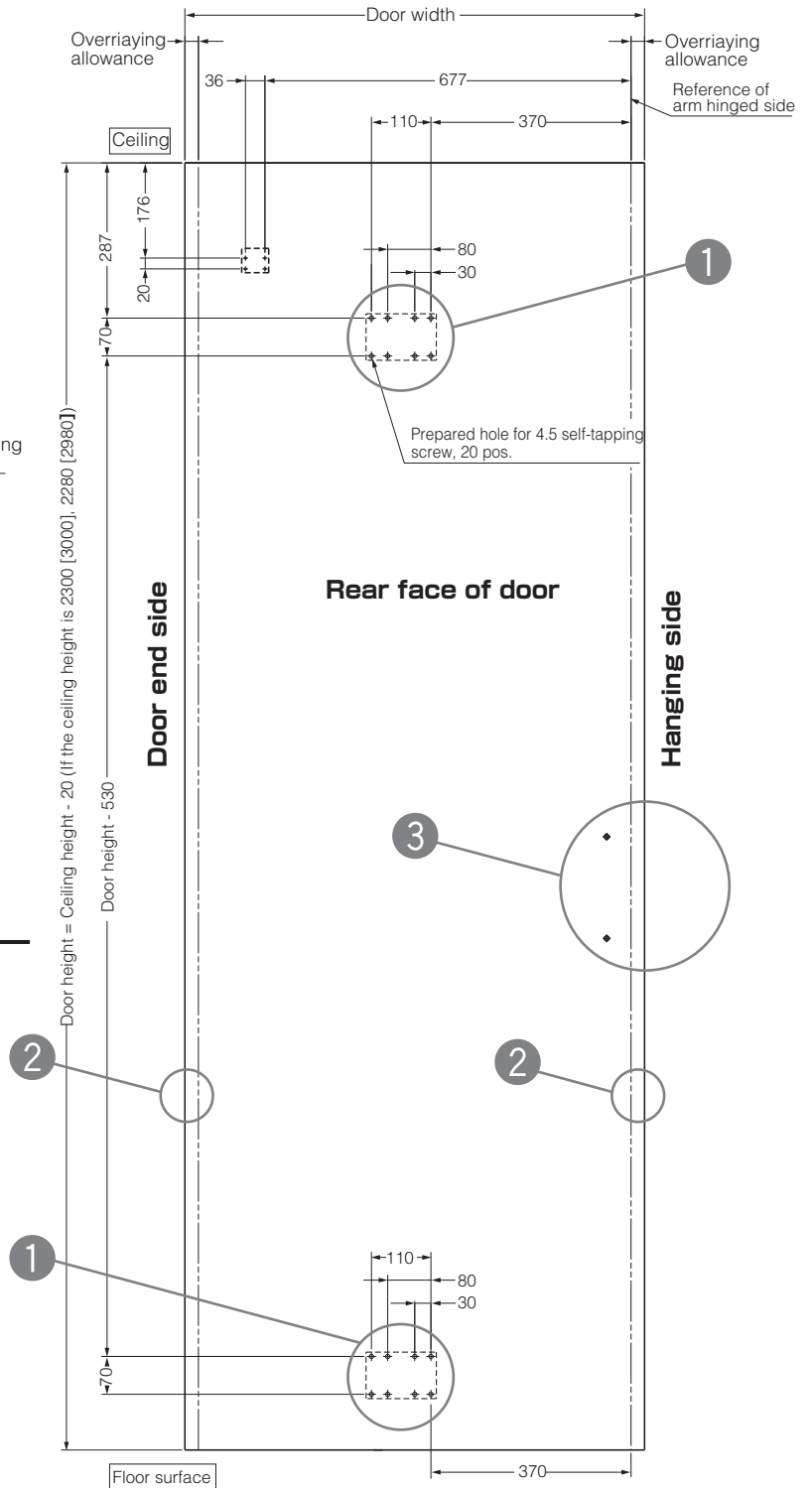

## 2 Sticking Brush seal

Stick the Brush seal to both edges on the rear face of the door.

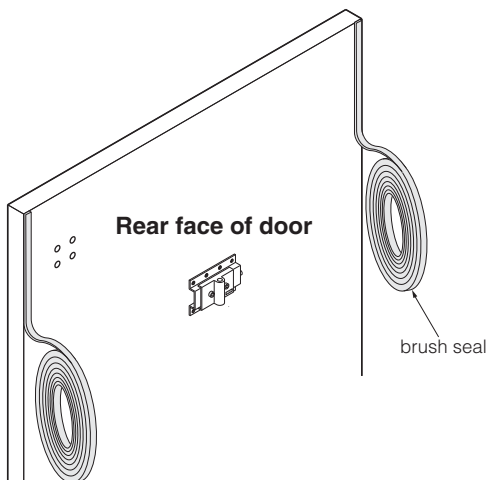

Working dimensional drawing of door

# 5 Installing door

## 1 Assembling Upper and Lower arms and Positioning unit

1. Open Upper and Lower arms to full opening position as below.  
The figure shows the Upper arm from underneath.

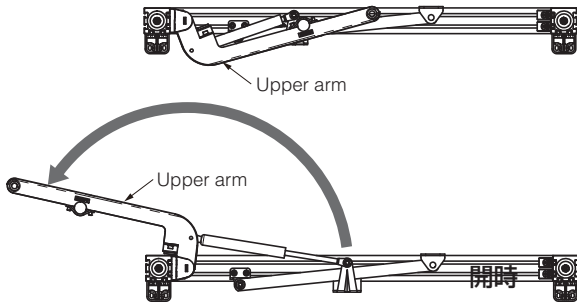

2. When hanging the door, place a support under the door.  
This is to protect the door and roughly match the height of Upper and Lower arms and Positioning units.

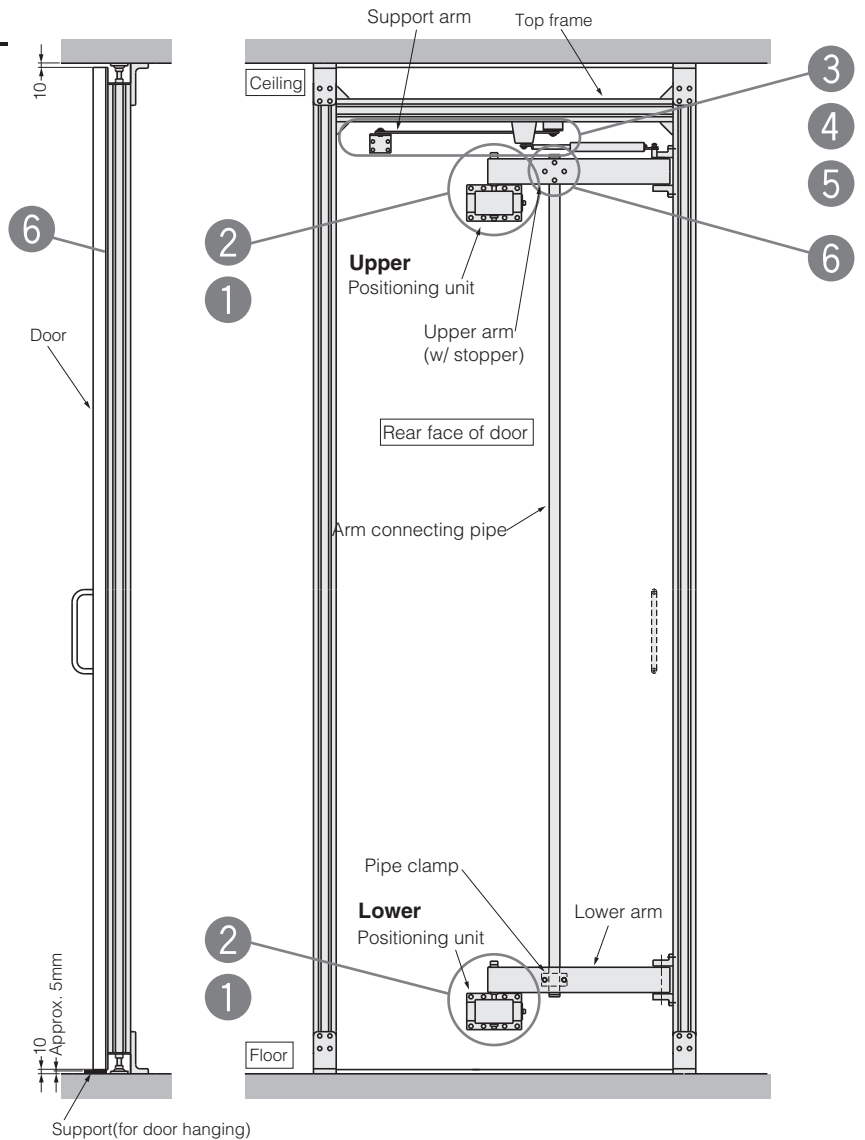

3. Hang the door in the following manner.
  - (1) Tighten the horizontal positioning screws on the Upper and Lower positioning units.
  - (2) Align the top surfaces of the Upper and Lower positioning units on the door with the bottom surfaces of the Upper and Lower arms.
  - (3) Insert a hexagon head bolt into the connecting hole with the flat washer.
  - (4) Screw the hexagon head bolt into the positioning unit until its leading end protrudes by about 10 mm.
  - (5) Screw a hexagon nut into position until it touches the positioning unit.



### Caution

Assemble the Upper arm and Upper positioning unit first, then assemble the Lower arm and Lower positioning unit.

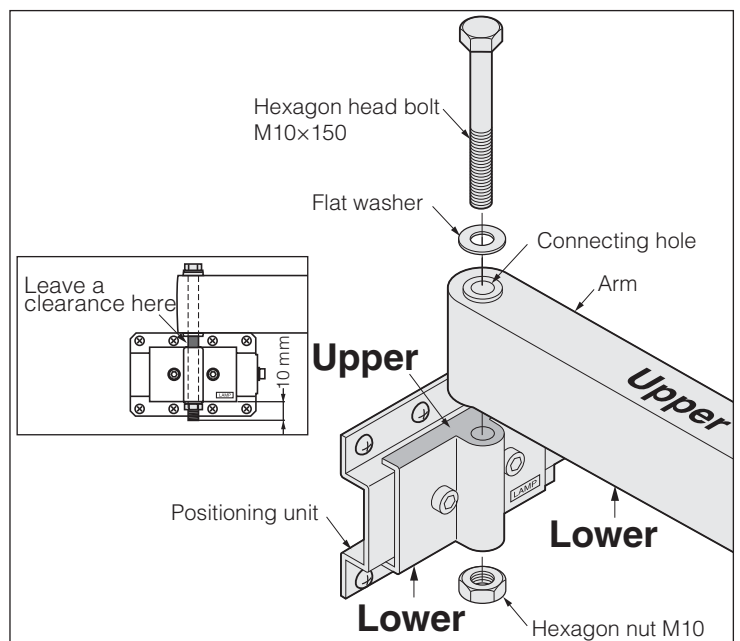



When positioning the door, be sure to loosen the hexagon socket head cap screw on the Support arm crank bracket (see P. 6 ④) to allow the bracket to move along the Channel rail.

## 2 Vertical positioning of door

Be sure that the aluminium frame is assembled vertically and horizontally.

1. Remove the support and close the door gently.
2. Measure the clearance between the top surface of the door and the top board.
  - (1) The difference between the planned dimension and the measurement is the required amount of adjustment.
  - (2) If there is no gap to correct, proceed to “③ Horizontal positioning of door.”
  - (3) Replace the support in the original position and open the door again.
    - Loosen the hexagon head bolt on the Upper and Lower arms a little.
    - Refer to the right figure and adjust the height. After the adjustment, turn the hexagon bolt on the Lower arm clockwise.
    - Close the door gently and check the height.
    - If the height is OK, tighten the hexagon nut.

### Caution

Note that there should be no gap between the Hexagon bolt and washer for both Upper and Lower arms.  
If any gap is found, tighten the Hexagon bolts so that the load on the two arms will be equal.

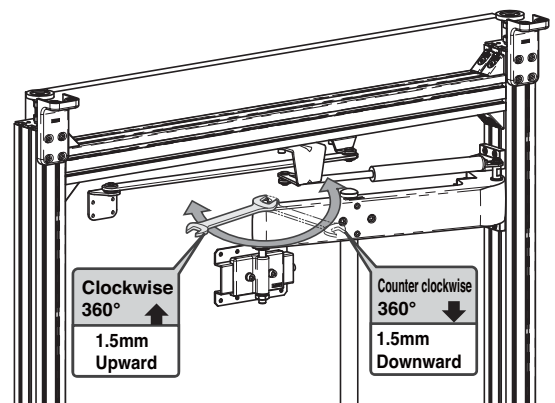
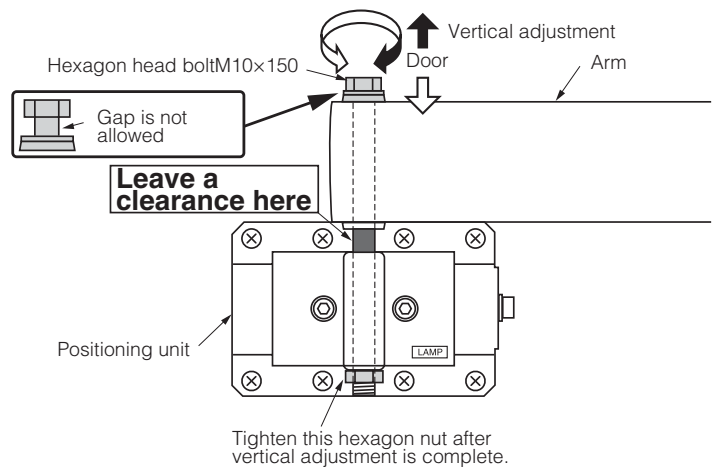

## 3 Horizontal positioning of door

1. Measure the horizontal gap between the door and frame. If there is any gap to be corrected, loosen the Hexagon socket head bolt on the Support arm crank bracket. (See P. 13 ④.)
2. Loosen the horizontal fixing screws on both Upper and Lower positioning units.
3. Turn the horizontal positioning screws.
  - (1) Turn the screws clockwise to move the door to the left or counterclockwise to move the door to the right when the door is viewed from the front.
  - (2) Retighten the positioning screws if the adjustment is OK.

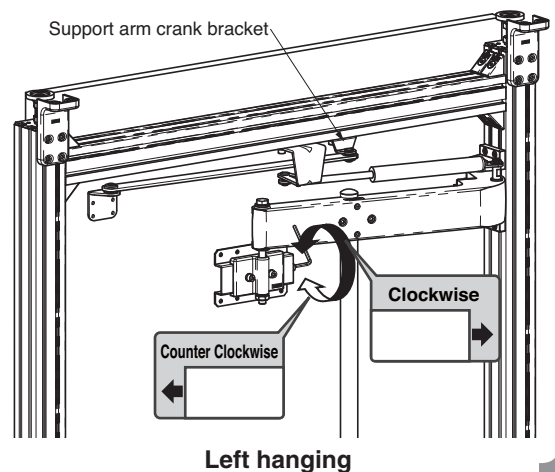
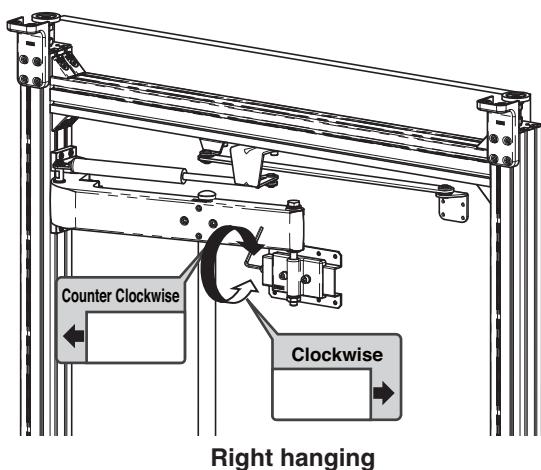
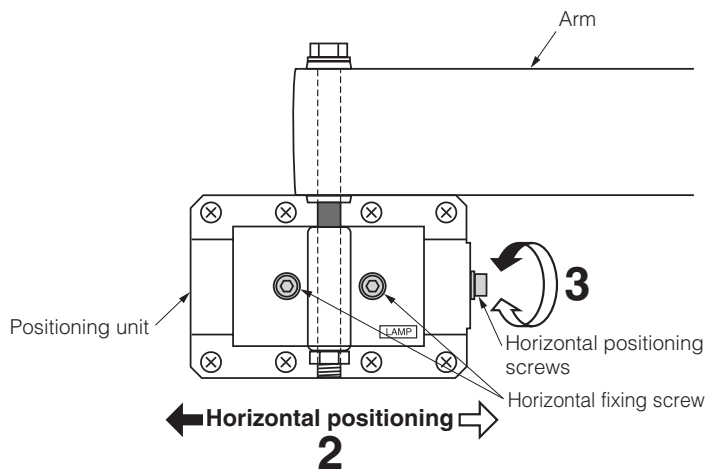

#### 4 Release Support arm crank bracket.

Loosen the hexagon socket head cap screws on the Support arm crank bracket, and allow the bracket to move along the Top frame.

#### 5 Fixing Support arm

Close the door completely, and fix the Support arm L-type bracket to the door with provided screws.



Be sure to face the pin of the crank bracket to as shown on the right drawing.

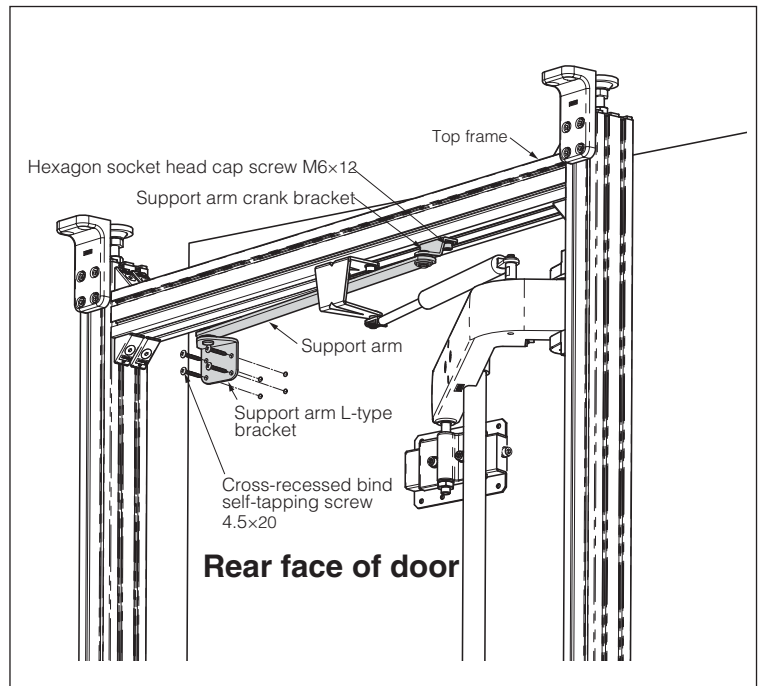

#### 6 Fix Support arm crank bracket.

Open the door slowly and fully and fix the Crank bracket.



When positioning the door, be sure to loosen the hexagon socket head cap screw on the Support arm crank bracket to allow the bracket to move along the Channel rail.

#### 7 Adjusting the gap between the vertical frame and door.

Loosen the screws on the Lower arm which fix the Arm connecting pipe. While keeping the door closed with no gap between the door and vertical frame, retighten the screws. If there is any gap left, adjust it by referring to "7 Troubleshooting [4]".

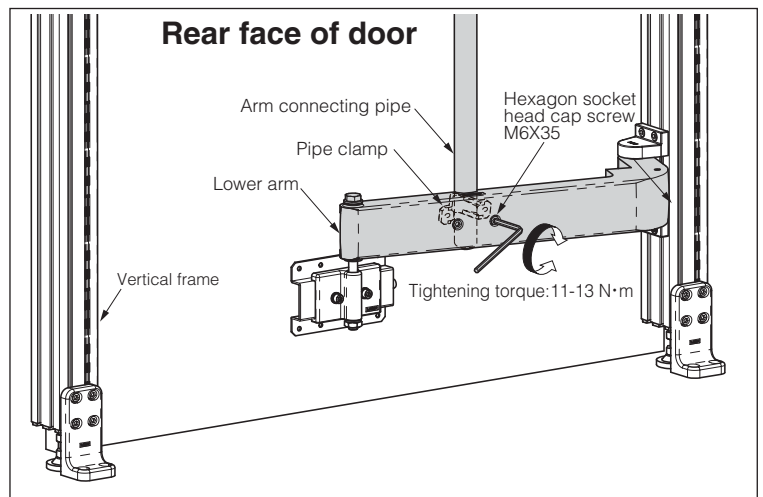

# 6 Installing Angle Joint (Installing Side Plate)

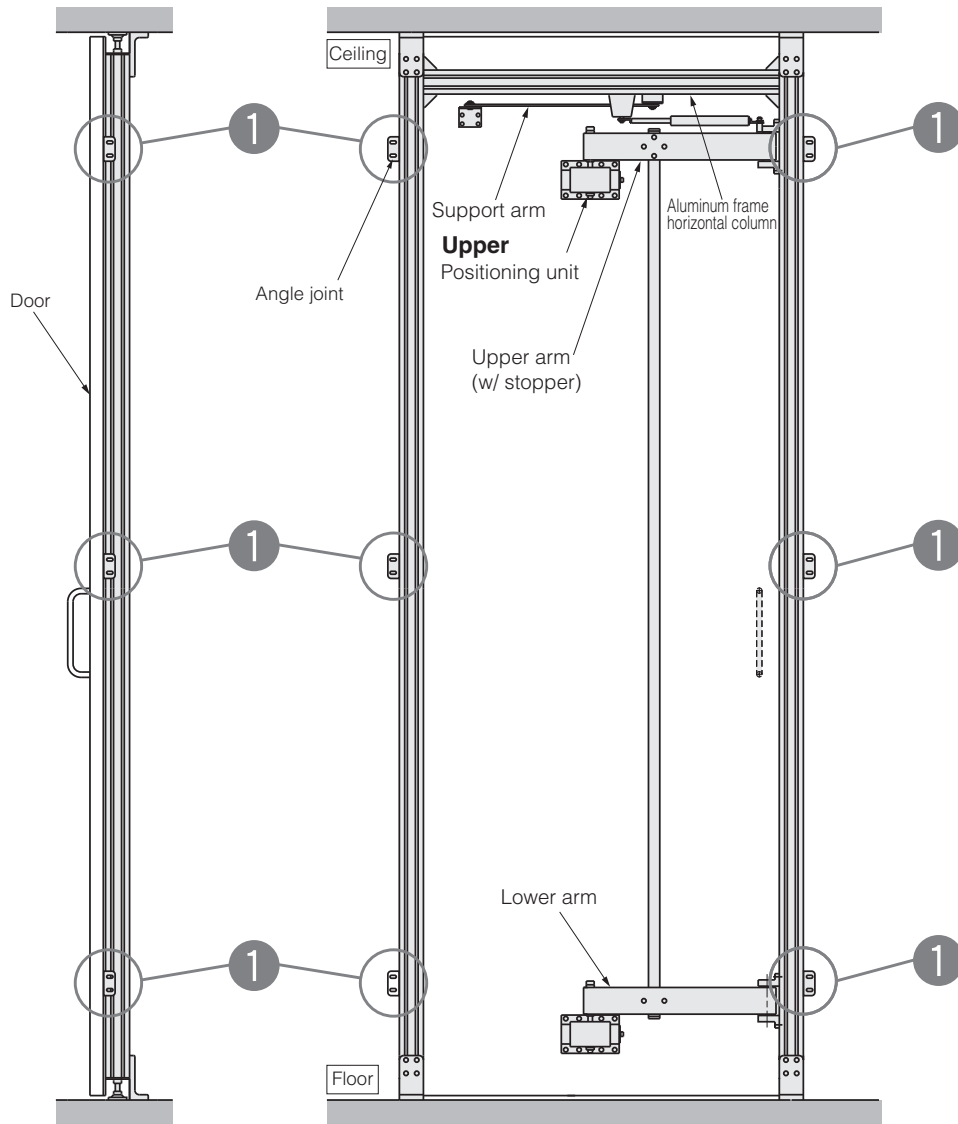

## 1 Fixing angle joint and side plate

When the side plate is installed, attach the "Angle joint" to the "Aluminum frame vertical column", and fix them to the side plate with the self-tapping screw or wooden screw of nominal size 5 or 6. Neither the self-tapping screw nor wooden screw is supplied.

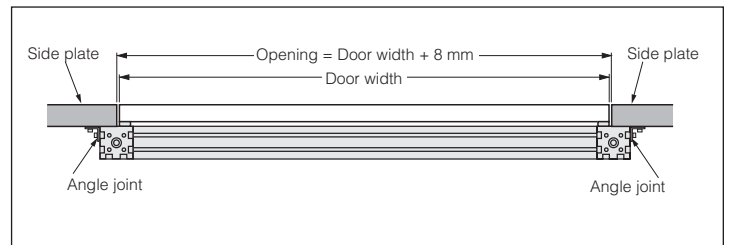
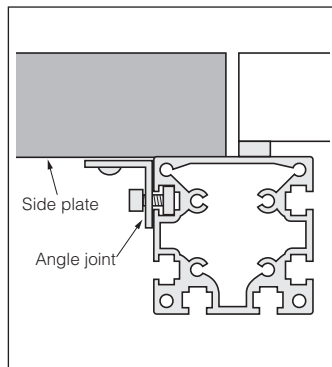
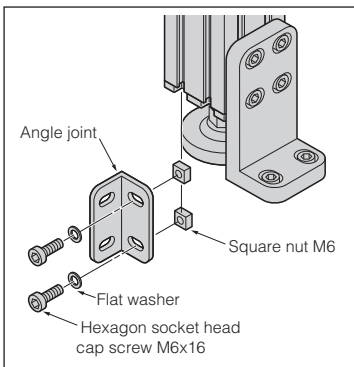

# 7 Troubleshooting

Video Link

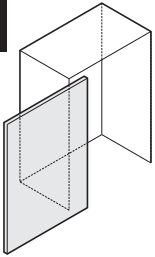

## [1] Large friction sound when opening/closing door

**Possible cause:**

Positioning unit may touch the arm.

**Solution:**

Refer to P. 12 ② and make a clearance between the Positioning unit and arm.

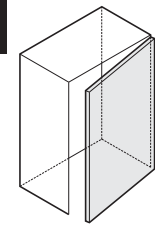
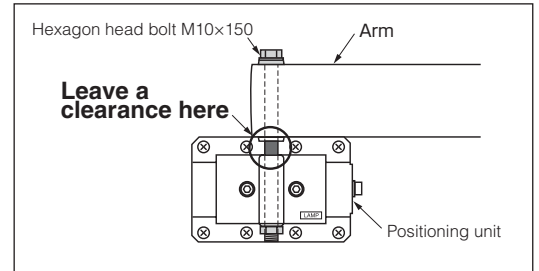

## [2] A gap remains between the side board and the door (hanging side) or it takes a long time to be closed.

**(1) In case of large gap**

Possible cause:

The position of Crank bracket may be improper.

Solution:

Loosen the screws on the bracket and move the bracket to the door-end direction. Then re-tighten the screws. (See P. 12.)

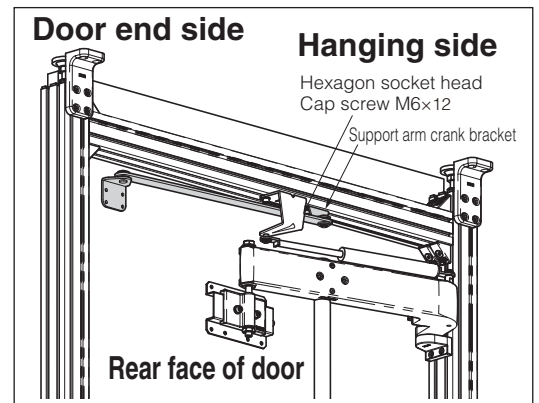

**(2) In case of small gap**

Possible cause:

Horizontal positioning of door may be improper.

Solution:

Loosen Horizontal fixing screws on the Positioning unit, then adjust the position by rotating the Horizontal positioning screw.

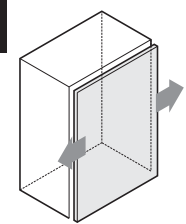
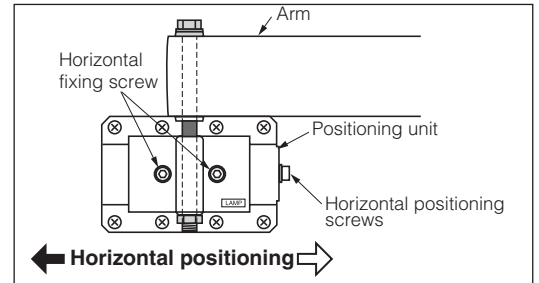

## [3] Gap between door and frame varies after horizontal positioning.

**Solution:**

**Check the following in order.**

(1) Vertical positioning, (2) Horizontal positioning (P.12), (3) Positioning of Crank bracket (P.13), and (4) Door close position adjuster screw A, B (P.15)

**Possible cause;**

If you adjust the vertical position or horizontal position in the last order, the gap between the door and frame may vary.

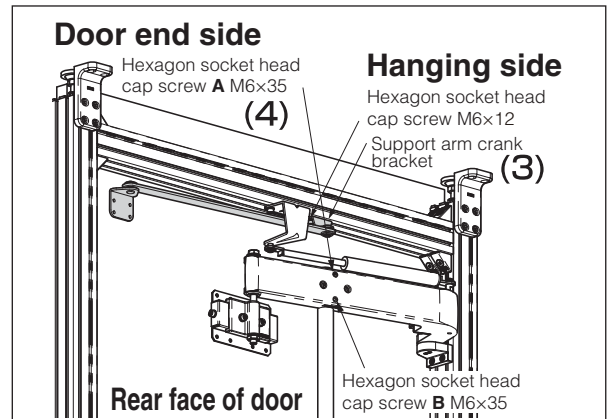
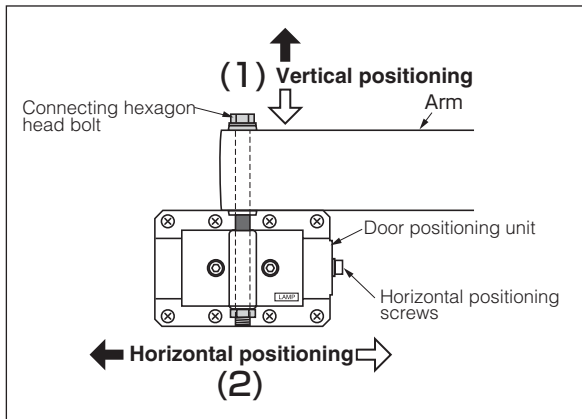

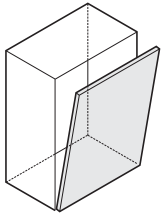

## [4] Gap between door and frame still remains

### Overview:

This system controls the slant of the door by bowing the Connecting pipe. Simply try the following method unsuspectingly.

Release the stress on Connecting pipe by loosening the 4 pcs of Hexagon socket head cap screws.

\*Also, loosen Door close position adjuster screw A and B, so that it make a clearance between the Upper arm and the Connecting pipe.

\*Adjustment need to be done from the space inside at the closed door.

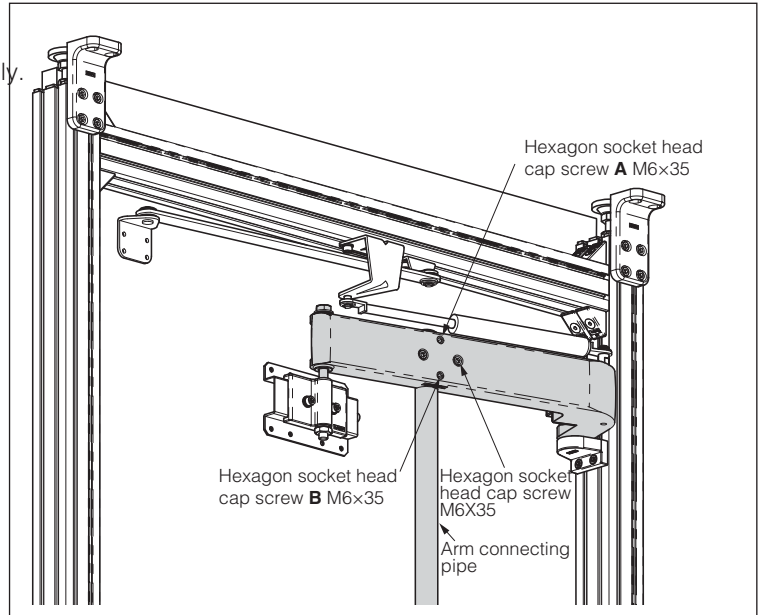

### Gap at the top

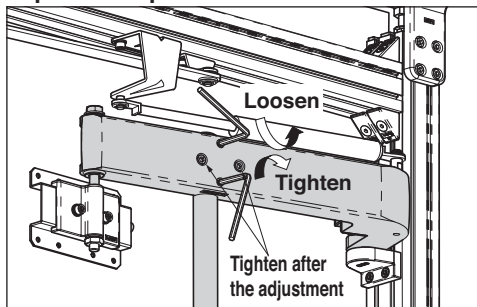

Tighten the Hexagon socket head cap screws on Lower arm. Adjustment would not be achieved if the screws on Lower arm were loose.

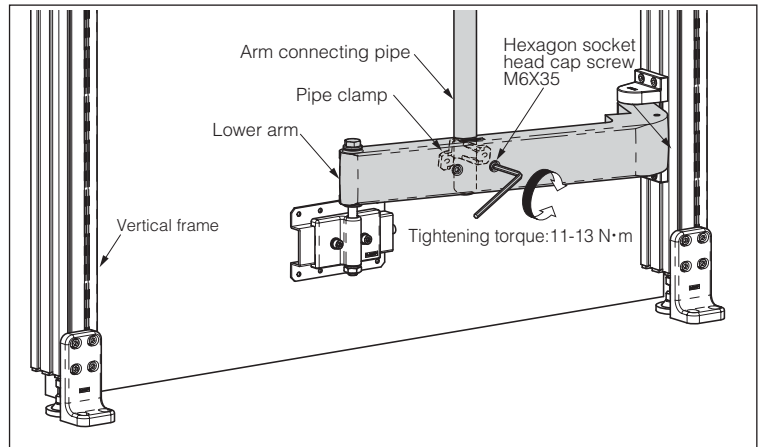

### Gap at the bottom

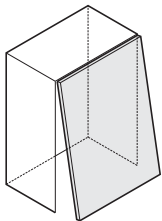
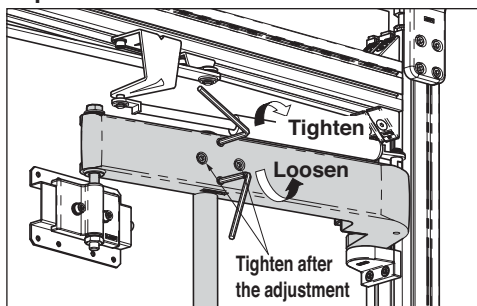

In case the gap still remains, even if the Connecting pipe is 7 or 8 mm apart from Upper arm, once loosen the Door position adjuster screw A and B completely, then tighten them until the Connecting pipe touches Upper arm. (See below figure.)

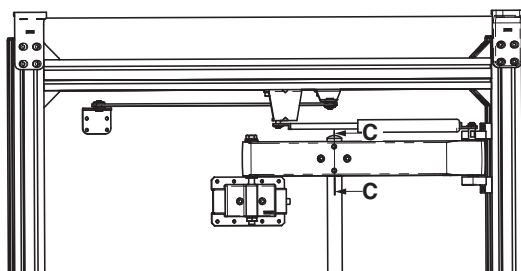

### Cross section C-C

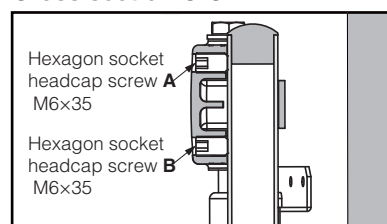



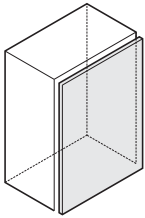

## [5] There are gaps on all four corners

### Possible cause:

Large doors are likely to warp, and perfect adjustment is not possible in case of a large warp.  
Adjust the gap between the door and the frame by attaching either the Brush seal or alternatively use "BS Bumpers" (sold separately).

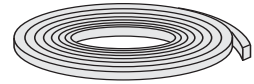

Brush seal  
FAD-54 : (5000 mm)×1  
FAD-54L : (6000 mm)×1

### In case the door bows inward.

It is not possible to make more than 2 corners to be contacted.

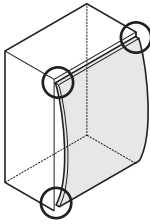

### In case the door bows outward.

It is not possible to make more than a corner to be contacted.

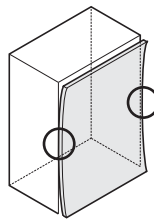

**BS Bumpers(sold separately)**  
You can choose various thickness.

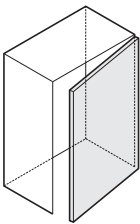

## [6] Out of alignment after using

### Possible cause:

The position of the handle may be improper.

The arm may be bent or out of alignment due to improper opening force if the handle is located far from the Hanging side.

Try the alignment.

If the parts are damaged. Contact us.

**SUGATSUNE KOGYO CO.,LTD**  
Tokyo, JAPAN  
Phone: +81 (0)3 3866 2260 E-mail:export@sugatsune.co.jp

**SUGATSUNE KOGYO (UK) LTD**  
Reading, UK  
Phone: +44 118 9272 955 E-mail:sales@sugatsune.co.uk

**SUGATSUNE EUROPE GmbH**  
Düsseldorf, GERMANY  
Phone: +49 211 53812900 E-mail:sales@sugatsune.eu

ISO9001(Japan Offices and Sugatsune America) and ISO14001(Chiba Production division and Logistics center), certified.

**SUGATSUNE SHANGHAI Co., LTD**  
Shanghai, CHINA  
Phone: +86 21 3632 1858 E-mail:lamp@sugatsune.com.cn

**Guangzhou, CHINA**  
Phone: +86 20 6639 3552 E-mail:lamp@sugatsune.com.cn

**SUGATSUNE KOGYO INDIA PRIVATE LIMITED**  
Mumbai, INDIA  
Phone: +91 22 28314490/91 E-mail:sales@sugatsune.in

**SUGATSUNE AMERICA, INC**  
California, USA  
Phone: +1 310 329 6373 E-mail:sales@sugatsune.com

**Chicago, USA**  
Phone: +1 312 461 1081 E-mail:chicagoshowroom@sugatsune.com.

**SUGATSUNE CANADA, INC.**  
Phone: +1 514 312 5267 E-mail:support@sugatsune.ca

2017.03 0214-4